

Arizona Representative
Measurement Solutions
Mark Anderson
480-897-0300
Magnetrol@MEASOL.com
<http://www.MEASOL.com>

Polaris™

Electromagnetic Flow Meter



The Polaris™ MA1 is the first liquid flow meter offered by Magnetrol®, expanding the already diverse level and flow measurement portfolio that has been established over the last 80 years.

Polaris™

Electromagnetic Flow Meter



The electromagnetic flow meter consists of a sensor through which the measured liquid flows and an electronic unit where the low-level signal from the sensor is modified to a standardized form suitable for further processing in various industrial electronic devices.

The output signal is proportional to the volumetric flow rate of the measured liquid. The only factor limiting the application of electromagnetic flow meters is the requirement that the measured liquid shall be conductive and non-magnetic.

The electromagnetic flow meter can be designed either as an integral device or with the sensor separated from the associated electronic unit. In the former case, the electronic unit is fitted directly onto the sensor, in the latter case it is connected to the sensor by a remote cable.

The sensor design shall take into consideration the type of the measured liquid and its operational parameters. To facilitate fitting into the liquid piping, the sensor can be provided with end flanges or as a wafer style design.

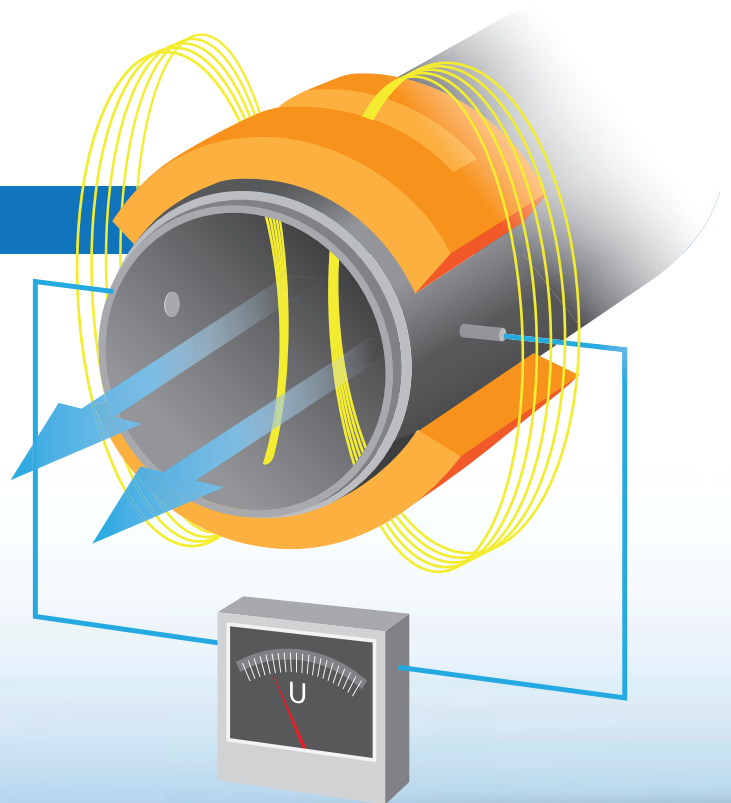

The function of an electromagnetic flow meter is based on Faraday's law of induction. The sensor consists of a non-magnetic and non-conductive tube with two embedded measuring electrodes. To create an alternating magnetic field, two coils are fitted onto the tube in parallel with the plane defined by the active parts of the measuring electrodes. If a conductive liquid flows across the magnetic field, a voltage will appear on the measuring electrodes proportional to the flow velocity and the conductor length.

Transmitter

Digits

4 | Power

0	115 VAC
1	230 VAC
2	24 VDC

5 | Outputs

1	4-20 mA with HART®, Pulse, Alarm (Status)
---	---

6 | Display

B	Display with keypad
---	---------------------

9 | Housing Location/Protection

1	Integral, IP67 transmitter
2	Remote transmitter with IP67 sensor*
3	Remote transmitter with IP68 sensor*

10 | Endlosure/Conduit Entries

0	Aluminum, 3/4" NPT
1	Aluminum, M20

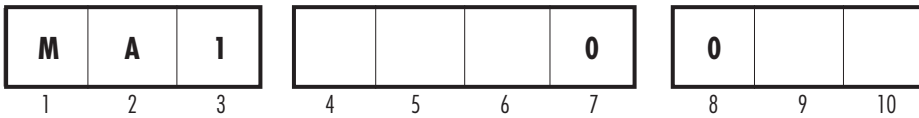

*Need to order remote cable

Remote Cable

Digits

7 | Units of Measurement

1	Feet
2	Meters

8 - 10 | Length**

020-164	If digit 7 = 1 (20 - 164 feet)
006-050	If digit 7 = 2 (6 - 50 meters)

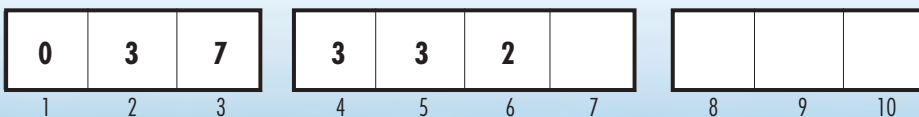

**Consult factory if conductivity is less than 50 µS/cm

Sensor

Digits

2 | Measurement System

- E** English: Sensor size in hundredths of an inch (use with ANSI or AWWA flanges)
- M** Metric: Sensor size in millimeters (use with DN flanges)

3 | Sensor Type

- 0** Wafer style sensor 3/4"–8" (DN20-200)
- 3** Flanged ANSI B16.5 or AWWA
- A** Flanged EN 1092-1

4-7 | Sensor Size (table below)

- 0050-3200** If digit 2 = E
- 0015-0800** If digit 2 = M

Sensor Table

Digit 2 = E			Digit 2 = M		
Size (in)	Code	Class	Size (DN)	Code	Class
1/2"	0050	ANSI 150#	15	0015	PN40
3/4"	0075	ANSI 150#	20	0020	PN40
1"	0100	ANSI 150#	25	0025	PN40
1 1/4"	0125	ANSI 150#	32	0032	PN40
1 1/2"	0150	ANSI 150#	40	0040	PN40
2"	0200	ANSI 150#	50	0050	PN40
2 1/2"	0250	ANSI 150#	65	0065	PN16
3"	0300	ANSI 150#	80	0080	PN16
4"	0400	ANSI 150#	100	0100	PN16
5"	0500	ANSI 150#	125	0125	PN16
6"	0600	ANSI 150#	150	0150	PN16
8"	0800	ANSI 150#	200	0200	PN16
10"	1000	ANSI 150#	250	0250	PN10
12"	1200	ANSI 150#	300	0300	PN10
14"	1400	ANSI 150#	350	0350	PN10
16"	1600	ANSI 150#	400	0400	PN10
20"	2000	ANSI 150#	500	0500	PN10
24"	2400	ANSI 150#	600	0600	PN10
28"	2800	AWWA (B)	700	0700	PN10
32"	3200	AWWA (B)	800	0800	PN6

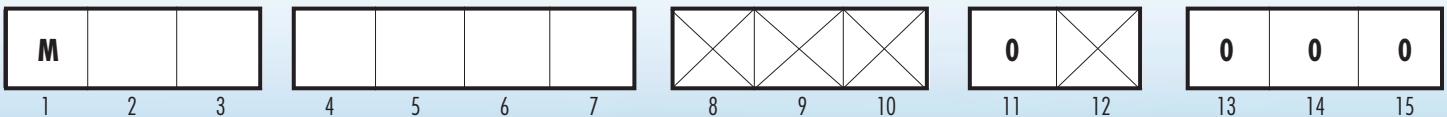

Sensor (cont.)

Digits

8 | Sensor Lining Material

1	Hard Rubber ¾"-32", +176°F max (DN20-800, +80°C max)
2	Soft Rubber ¾"-32", +176°F max (DN20-800, +80°C max)
3	PTFE ½"-10", +302°F max (DN15-250, +150°C max)
4	ECTFE 12"-32", +266°F max (DN300-800, +130°C max)

9 | Material of Electrodes

A	Stainless Steel (standard with rubber liners)
B	Hastelloy® C (standard with PTFE or ECTFE liners)

10 | Material of Cover and Flanges*

A	Carbon Steel cover and Stainless Steel flanges
0	Wafer style with Carbon Steel cover
1	Carbon Steel cover and Carbon Steel flanges (standard)

12 | Optional Grounding Rings

A	None – 3rd grounding electrode provided for ¾" + (DN20+)
B	Provide

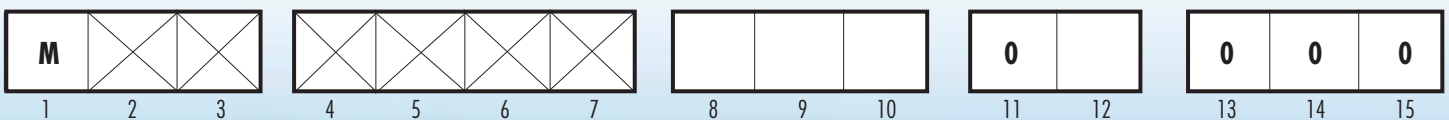

*Spool piece is always SS

Dimensions and Ratings of Flanged Sensor

Sensor dimensions (inches) for various rated diameters

Flanges according to ANSI B16.5 (150#) and AWWA Class B

	DN	D	d	A*	L	I	Wt. (lb.)**
ANSI (max. working pressure 230 psi)	½"	3.5	2.4	6.8	7.9	2.6	7
	¾"	3.88	2.4	7.0	7.9	2.6	7
	1"	4.25	2.8	7.4	7.9	3.8	7
	1 ¼"	4.63	3.2	7.8	7.9	3.8	9
	1 ½"	5	3.6	8.2	7.9	3.8	9
	2"	6	4.2	8.9	7.9	3.8	13
	2 ½"	7	5.0	9.8	7.9	3.8	20
	3"	7.5	5.6	10.4	7.9	3.8	31
	4"	9	6.4	11.5	9.8	3.8	35
	5"	10	7.6	12.6	9.8	5.0	42
ANSI (max. working pressure 150 psi)	12"	19	16.5	21.6	19.7	12.6	170
	14"	21	18.9	23.8	21.7	12.6	203
	16"	23.5	20.9	26.0	23.6	12.6	256
	20"	27.5	25.2	30.2	23.6	12.6	368
	24"	32	29.9	34.8	23.6	12.6	694
AWWA (max. working pressure 86 psi)	28"	36.5	34.0	39.1	27.6	16.5	794
	32"	41.75	37.7	43.5	31.5	16.5	941

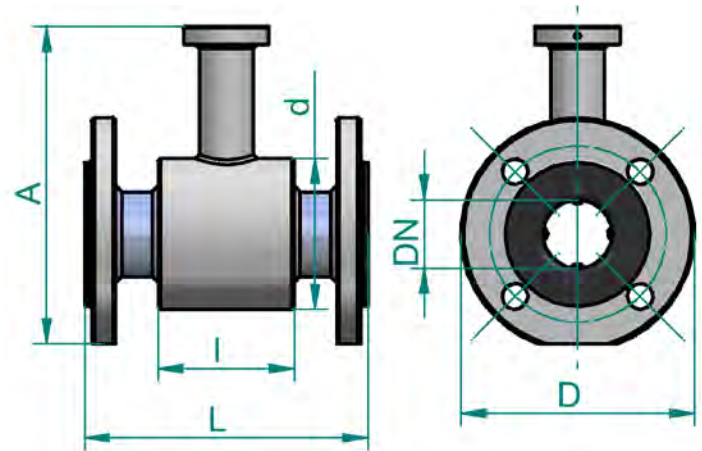

Sensor dimensions (mm) for various rated diameters (DN)

Flanges according to standard CSN EN 1092-1

	DN	D	d	A*	L	I	Wt. (kg)**
PN 40	15	95	62	164	200	66	3
	20	105	62	170	200	66	3
	25	115	72	180	200	96	3
	32	140	82	199	200	96	4
	40	150	92	209	200	96	4
PN 16	50	165	107	223	200	96	6
	65	185	127	244	200	96	9
	80	200	142	260	200	96	14
	100	220	162	280	250	96	16
	125	250	192	310	250	126	19
	150	285	218	340	300	126	25
PN 10	200	340	274	398	350	211	41
	250	395	370	480	450	211	54
	300	445	420	535	500	320	77
	350	505	480	584	550	320	92
	400	565	530	642	600	320	116
	500	670	640	752	600	320	167
	600	780	760	870	600	320	315
700	895	880	990	700	420	357	
PN 6	800	975	960	1100	800	420	427

* Dimension A (sensor height) is net of the electronic unit box (or terminal box in the distributed meter version).

** The sensor weight data are only approximate.

Dimensions of wafer sensor inches (mm)

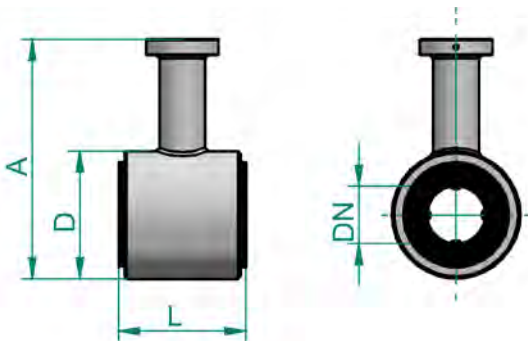

DN	D	A*	L
¾" (20)	2.4 (62)	5.7 (145)	2.9 (74)
1" (25)	3.8 (72)	6.2 (158)	4.1 (104)
1 ¼" (32)	3.2 (82)	6.6 (168)	4.1 (104)
1 ½" (40)	3.6 (92)	7.0 (179)	4.1 (104)
2" (50)	4.2 (107)	7.6 (192)	4.1 (104)
2 ½" (65)	5.0 (127)	8.3 (212)	4.1 (104)
4" (100)	6.4 (162)	9.7 (247)	4.1 (104)
5" (125)	7.6 (192)	10.9 (277)	5.3 (134)
6" (150)	8.6 (218)	11.9 (303)	5.3 (134)
8" (200)	10.8 (274)	14.1 (359)	8.6 (219)

Transmitter dimensions

Height	5 ⅞" (150 mm)
Length	8 ⅞" (207 mm)

Performance

Range	0.33 – 32.8 ft/s (0.1 – 10 m/s)
Accuracy	0.3% of reading for 5 to 100% Qmax
Repeatability	0.15% of reading

Transmitter

Power source	230 VAC (+10% / -15%) / 50/60 Hz 115 VAC (+10% / -15%) / 50/60 Hz 24 VDC (±15%)
Power consumption	AC = 10 VA; DC = 10 W
Housing material	Aluminum
Ambient temperature	-4°F (-20°C)* to 140°F (60°C)
Outputs	
Analog (active)	0/4–20 mA (isolated)
Pulse (passive)	24V, 60 mA (isolated)
Status (passive)	24V, 60 mA (isolated)
Communication	Keypad on display, HART protocol for use with PACTware™
Menu language	English, German
Protection class	IP 67
Empty pipe detection	At measuring electrodes, selectable on/off

*Display may not read under this value but the outputs will still function

Sensor

Sensor size	Flanged, ½" (DN15) to 32" (DN800) Wafer, ¾" (DN20) to 8" (DN200)
Flanges	ANSI B16.5 (150#) and AWWA (B) or EN 1092-1 Carbon Steel standard; optional 304 Stainless Steel
Grounding	Grounding electrode provided for ¾" (DN20) and larger Optional grounding rings (304 Stainless Steel)
Maximum operating temperature of liquid	+302°F (+150°C)** – liner dependent
Minimum conductivity of liquid	20 µS/cm; consult factory for down to 5 µS/cm
Lining	Hard rubber +32°F (0°C) to +176°F (+80°C), size ¾"– 32" (DN20-DN800) Soft rubber 32°F (0°C) to +176°F (+80°C), size ¾"– 32" (DN20-DN800) PTFE -4°F (-20°C) to +302°F (+150°C), size ½"– 10" (DN15-DN250) ECTFE -4°F (-20°C) to +266°F (+130°C), size 12"– 32" (DN300-DN800)
Measuring electrodes	316 Stainless Steel – standard with rubber liner Hastelloy C4 – standard with PTFE or ECTFE liner Other options available as a special
Pipe spool material	304 Stainless Steel
Sensor cover	Carbon Steel
Protection class	IP67 or IP68

**For liquid temperatures greater than 212°F (100°C) use a remote transmitter



Polaris™

Electromagnetic Flow Meter

- 4-20 mA, pulse, and alarm outputs
- Liquid conductivity down to 5 $\mu\text{S}/\text{cm}$
- Forward and reverse flow indication
- Multiple liner and electrode options
- HART protocol for use with PACTware™
- Flanged or wafer style sensors

**A world of level,
flow and volume
solutions**

For more information, please visit us at water.magnetrol.com

Arizona Representative
Measurement Solutions
Mark Anderson 480-897-0300
Magnetrol@MEASOL.com
<http://www.MEASOL.com>



CORPORATE HEADQUARTERS

705 Enterprise Street • Aurora, Illinois 60504-8149 • Phone: 630-969-4000 • Fax: 630-969-9489

magnetrol.com • info@magnetrol.com

EUROPEAN HEADQUARTERS

Heikensstraat 6 • 9240 Zele, Belgium • Phone: 052 45.11.11 • Fax: 052 45.09.93

Arizona Representative
Measurement Solutions
Mark Anderson 480-897-0300
Magnetrol@MEASOL.com
<http://www.MEASOL.com>

Magnetrol & Magnetrol logotype are registered trademarks of Magnetrol International, Incorporated.

Copyright © 2013 Magnetrol International, Incorporated. All rights reserved. Printed in the USA.

Bulletin: 62-101.0 • Effective: August 2013

