

# Polaris™

Electromagnetic Flow Meter

Polaris MA1

Installation and Operating Manual





# Content

<b>1. APPLICATION .....</b>	<b>5</b>
<b>2. MEASUREMENT PRINCIPLE .....</b>	<b>5</b>
<b>3. TECHNICAL DESCRIPTION .....</b>	<b>6</b>
<b>4. SENSOR TECHNICAL PARAMETERS .....</b>	<b>6</b>
4.1. SELECTION OF CORRECT SENSOR SIZE .....	6
4.2. SELECTION OF ELECTRODE MATERIAL .....	7
4.3. SELECTION OF SENSOR TUBE LINING .....	7
4.4. INTEGRAL OR REMOTE METER VERSION .....	8
4.4.1 <i>Remote version</i> .....	8
4.5. DIMENSIONS OF FLANGED SENSOR .....	10
4.6. DIMENSIONS OF FLANGELESS SENSOR .....	12
4.7. CRITICAL DIMENSIONS OF TRANSMITTER .....	12
4.8. SPECIFICATIONS .....	13
<b>5. COMISSIONING .....</b>	<b>14</b>
5.1 INSTALLATION OF ELECTROMAGNETIC FLOW METERS .....	14
<b>6. MA1 TRANSMITTER: MODE OF OPERATION AND CONFIGURATION .....</b>	<b>18</b>
6.1 SYSTEM DESIGN .....	18
6.1.1 <i>Data memory chip DSM</i> .....	18
6.1.2 <i>Safety of operation</i> .....	19
<b>7. OUTPUT .....</b>	<b>20</b>
7.1 OUTPUT SIGNAL .....	20
7.2 FAILURE SIGNAL .....	20
7.3 LOAD OF THE CURRENT OUTPUT .....	20
7.4 DAMPING .....	21
7.5 LOW FLOW CUT-OFF .....	21
<b>8. MA1 PERFORMANCE CHARACTERISTICS .....</b>	<b>21</b>
8.1 REFERENCE CONDITIONS .....	21
8.2 MEASURING TOLERANCE .....	21
8.3 REPEATABILITY .....	21
8.4 INFLUENCE OF AMBIENT TEMPERATURE .....	21
<b>9. MA1 OPERATING CONDITIONS .....</b>	<b>22</b>
9.1 ENVIRONMENTAL CONDITIONS .....	22
9.1.1 <i>Degree of protection</i> .....	22
9.2 PROCESS CONDITIONS .....	22
9.2.1 <i>Fluid temperature</i> .....	22
9.2.2 <i>State of aggregation</i> .....	22
9.2.3 <i>Viscosity</i> .....	22
9.2.4 <i>Fluid temperature limit</i> .....	22
9.2.5 <i>Flow rate limit</i> .....	22
9.2.6 <i>Pressure loss</i> .....	22
9.2.7 <i>Empty pipe detection</i> .....	23
<b>10. MA1 ELECTRICAL CONNECTIONS .....</b>	<b>23</b>
10.1 ELECTRICAL CONNECTIONS .....	23
<i>HART® connection</i> .....	24
10.2 REMOTE VERSION .....	24
<b>11. MAINTENANCE AND REPAIR .....</b>	<b>25</b>
11.1 REPLACING THE TRANSMITTER .....	25
<b>12. MA1 MENU STRUCTURE .....</b>	<b>26</b>
12.1 INTRODUCTION .....	26
12.2 DISPLAY .....	26
12.3 OPERATING MODES .....	26
12.4 OPERATION .....	27
12.4.1 <i>Operation interface</i> .....	27
12.4.2 <i>The keys and their functions</i> .....	27
12.4.3 <i>Functional classes, functions and parameters</i> .....	28
12.4.3.1 <i>Selection window / make a selection</i> .....	28
12.4.3.2 <i>Input window / modify a value</i> .....	28

12.4.3.3 Passwords.....	28
13.1 MEASURED VALUES FUNCTIONAL CLASS.....	30
13.1.1 Volume flow rate.....	31
13.1.2 Forward flow counter 1.....	31
13.1.3 Forward flow counter 2.....	31
13.1.4 Reverse flow counter.....	31
13.1.5 Flow velocity.....	31
13.1.6 Relative flow rate.....	31
13.1.7 QV + Forward flow counter.....	32
13.1.8 QV + Forward flow counter 2.....	32
13.1.9 QV + flow velocity.....	32
13.1.10 Display mode during startup.....	33
13.1.11 Raw values.....	33
13.2 PASSWORD FUNCTIONAL CLASS.....	34
13.2.1 Customer-password.....	34
13.2.2 Change customer password.....	35
13.2.3 Service password.....	35
13.3 COUNTER FUNCTIONAL CLASS.....	36
13.3.1 Unit of counters.....	37
13.3.2 Reset counter.....	37
13.4 MEASUREMENT PROCESSING FUNCTIONAL CLASS.....	38
13.4.1 Damping.....	39
13.4.2 Low flow cut-off.....	39
13.4.3 Low flow cut-off hysteresis.....	39
13.5 FLOW FUNCTIONAL CLASS.....	40
13.5.1 Volume flow QV unit.....	41
13.5.2 Volume flow lower-range value.....	41
13.5.3 Volume flow upper-range value.....	41
13.5.4 Volume flow limit MIN.....	42
13.5.5 Volume flow limit MAX.....	42
13.5.6 QV limit hysteresis.....	42
13.5.7 Density.....	43
13.5.8 Volume flow LSL (information field).....	43
13.5.9 Volume flow USL (information field).....	43
13.6 PULSE OUTPUT FUNCTIONAL CLASS.....	44
13.6.1 Pulse Output.....	45
13.6.2 Pulse output unit.....	45
13.6.3 Pulse value.....	45
13.6.4 Pulse width.....	45
13.7 STATUS OUTPUT FUNCTIONAL CLASS.....	46
13.7.1 Status output active state.....	46
13.7.2 Status output assignment.....	47
13.8 CURRENT OUTPUT FUNCTIONAL CLASS.....	48
13.8.1 Current output 0/4 - 20 mA.....	48
13.8.2 Current output alarm.....	49
13.9 SIMULATION FUNCTIONAL CLASS.....	50
13.9.1 Simulation on / off.....	51
13.9.2 Simulation direct / preset value Q.....	51
13.9.3 Simulation measured flow Q.....	51
13.9.4 Direct simulation of outputs.....	51
13.9.4.1 Status output simulation.....	52
13.9.4.2 Pulse output simulation.....	52
13.9.4.3 Current output simulation.....	52
13.10 SELF-TEST FUNCTIONAL CLASS.....	53
13.10.1 Self-test test on / off.....	54
13.10.2 Self-test period (STP).....	54
13.10.3 Reference calibration on / off.....	54
13.10.4 Reference calibration period (GAP).....	55
13.10.5 Empty pipe detection on / off.....	55
13.10.6 Empty pipe detection period.....	55
13.11 SETTINGS SENSOR + MA1 FUNCTIONAL CLASS.....	56
13.11.1 Sensor constant C.....	57
13.11.2 Sensor type.....	57
13.11.3 Inside diameter.....	57
13.11.4 Language.....	58
13.11.5 Excitation frequency.....	58
13.11.6 Mains frequency.....	58

13.11.7 Flow direction.....	57
13.11.8 Software version (information field).....	58
13.11.9 Serial number (information field).....	58
13.11.10 Show system errors.....	58
13.11.11 Reset system error.....	59
<b>14. MA1 ERROR MESSAGES .....</b>	<b>59</b>
14.1 LIST OF ERROR MESSAGES .....	59
14.1.1 Display of self-test errors .....	59
14.1.2 Display of system error.....	60
14.1.3 Reset system error.....	60
<b>15. WARRANTY.....</b>	<b>61</b>

## 1. APPLICATION

The POLARIS MA1 electromagnetic flow meter has been designed to measure volume flow rates of electrically conductive liquids in closed piping systems. Measurements can be done in both flow directions, with high measurement accuracy over a wide range of flow rates. The minimum required conductivity of the measured medium is 5  $\mu\text{S}/\text{cm}$ .

The microprocessor controlled MA1 transmitter processes measurement data and displays and transmits various types of measurement results. The MA1 supports the option of HART<sup>®</sup> communication protocol for use with PACTware. Although basic configuration settings such as transmitter calibration are defined at the factory, other settings such as those for measurement data processing, analysis, display and output are user definable.

User settings are protected by a user definable password.

Settings that are essential for proper operation of the transmitter in conjunction with the sensor (e.g. calibration and initialization values) are accessible only to service technicians via a password that is not provided to customers.

## 2. MEASUREMENT PRINCIPLE

The function of an electromagnetic flow meter is based on Faraday's electromagnetic law. The meter sensor consists of a non-magnetic and non-conductive tube with two embedded measuring electrodes to pick up the induced voltage. To create an alternating magnetic field, two coils are fitted onto the tube in parallel with the plane defined by the active parts of the measuring electrodes. Now if a conductive liquid flows across magnetic field **B**, voltage **U** will appear on the measuring electrodes proportional to the flow velocity **v** and the conductor length **l**.

$$U = B \times l \times v$$

- U** induced voltage
- B** magnetic flux density
- l** distance between the measuring electrodes
- v** liquid flow velocity

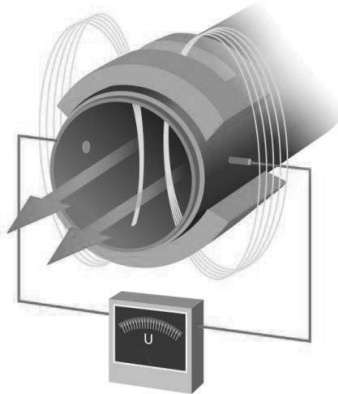

Figure 1 □ Measurement principle

As the magnetic flux density and distance between the electrodes are constant, the induced voltage is proportional to the liquid flow velocity in the tube. The value of the volume flow rate can then be readily determined as a product of the flow velocity and square section of the tube,  $Q = v \times A$ .

### **3. TECHNICAL DESCRIPTION**

The electromagnetic flow meter consists of a sensor through which the measured liquid flows and an electronic unit where the low-level signal from the sensor is modified to a standardised form suitable for further processing in various industrial electronic devices. The output signal is proportional to the volume flow rate of the measured liquid. The only factor limiting the application of electromagnetic flow meters is the requirement that the measured liquid shall be conductive and non-magnetic. The electromagnetic flow meter can be designed either as an integral device or with the sensor separated from the associated electronic unit. In the former case, the electronic unit is fitted directly onto the meter sensor, in the latter case it is connected to the sensor by a special cable.

The sensor design shall take into consideration the type of the measured liquid and its operational parameters. To facilitate fitting into the liquid piping, the sensor can be provided with end flanges or as a wafer style design. The supply voltage, types of output signal and communication interface can be selected according to the customer requirements.

### **4. SENSOR TECHNICAL PARAMETERS**

The sensor environment must be free of any strong magnetic fields.

#### ***4.1. Selection of correct sensor size***

The following table shows minimum and maximum flow rates for various sensor sizes and flow velocities ranging from 0.33-33 ft/s (0.1-10 m/s). The best operational properties will be achieved at the flow velocity range of 1.64-16.4 ft/s (0.5 to 5 m/s). The measurement accuracy is degraded at lower velocities while at higher velocities the turbulences and contact edges may cause undesirable interference.

#### **Minimum and maximum flow rates for various sensor sizes**

Qmin corresponds to flow velocity 0.33 ft/s (0.1 m/s)

Qmax corresponds to flow velocity 33 ft/s (10.0 m/s)

**Table 1 - Minimum and Maximum Flow Rates**

Size (in)	Size (DN)	Min (GPM)	Max (GPM)	Min (m3/h)	Max (m3/h)	Min (l/s)	Max (l/s)
1/2"	15	0.29	28.5	0.065	6.5	0.018	1.8
3/4"	20	0.53	52.8	0.12	12	0.033	3.3
1"	25	0.79	79.3	0.18	18	0.05	5
1-1/4"	32	1.32	132.0	0.3	30	0.083	8.3
1-1/2"	40	1.98	198.1	0.45	45	0.125	12.5
2"	50	3.17	317.0	0.72	72	0.2	20
2-1/2"	65	5.28	528.3	1.2	120	0.333	33.3
3"	80	7.93	792.5	1.8	180	0.5	50
4"	100	12.33	1232.7	2.8	280	0.778	77.8
5"	125	18.93	1893.2	4.3	430	1.194	119.4
6"	150	28.62	2861.8	6.5	650	1.806	180.6
8"	200	50.63	5062.6	11.5	1150	3.194	319.4
10"	250	79.25	7925.2	18	1800	5	500
12"	300	110.95	11095.2	25.2	2520	7	700
14"	350	154.07	15406.5	35	3500	9.72	972
16"	400	198.13	19812.9	45	4500	12.5	1250
20"	500	317.01	31700.7	72	7200	20	2000
24"	600	440.32	44032.2	100	10000	27.78	2778
28"	700	616.42	61641.9	140	14000	38.89	3889
32"	800	792.52	79251.6	180	18000	50	5000

#### **4.2. Selection of electrode material**

In most cases, electrodes made of stainless steel, quality grade 1.4571 (17248) are satisfactory. These electrodes come standard for the rubber liners. For more corrosive applications it may be desired to go to Hastelloy C4 electrodes, which are standard with the PTFE and ECTFE liners. On request, tantalum or titanium electrodes can be provided.

#### **4.3. Selection of sensor tube lining**

The sensor lining material selection depends on the operational parameters of the measured liquid.

##### **Technical rubber**

This lining material is suitable for less corrosive liquids and operational temperatures from +32°F (0°C) to +176°F (+80°C). It is sufficient for most applications in water supply and waste water treatment plants. Technical rubber is available as hard rubber or soft rubber. Soft rubber lining is recommended for liquids containing abrasive particles, such as sand grains.

##### **PTFE**

A universal solution for highly corrosive liquids and temperatures ranging from -4°F (-20°C) to +302°F (+150°C). Typical applications are in the chemical and food processing industries.

##### **ECTFE**

A similar solution as PTFE except used for larger line sizes. Temperature range from -4°F (-20°C) to +266°F (+130°C).



#### 4.4. Integral or remote meter version

The Electronic unit can be installed directly on the sensor (integral version) observing the operating conditions of the sensor or be mounted separately on the outside (remote version).

##### 4.4.1 Remote version

The remote meter version is to be used at the measurement spots with ambient temperature exceeding 140°F (60°C) where the reliable function of the electronic unit would not be ensured at all times. In such cases, use the remote meter version and place the separate electronic unit at a location where the ambient temperature never exceeds this rating. For process temperatures higher than 212°F (100°C) it is recommended to use the remote version.

Furthermore, the transmitter needs to be mounted separately from the sensor if

- the mounting area is difficult to access
- there is a lack of space
- there is strong vibration

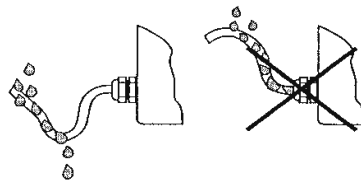

**Figure 2 - Proper installation of cables at high humidity and wetness**

The Electronic unit has to be mounted free of vibrations!

	<p style="text-align: center;"><u>Caution:</u></p> <ul style="list-style-type: none"><li>• The electrode cable must be fixed. If the conductivity of the medium is low, cable movements may change the capacity considerably and thus disturb the measuring signal.</li><li>• Do not lay the cables close to electrical machines and switching elements.</li><li>• Equipotential bonding must be ensured between sensor and transmitter.</li><li>• Do not connect or disconnect the field coil cable before the primary power of the meter has been disconnected.</li></ul>
--	-----------------------------------------------------------------------------------------------------------------------------------------------------------------------------------------------------------------------------------------------------------------------------------------------------------------------------------------------------------------------------------------------------------------------------------------------------------------------------------------------------------------------------------------------------------------------------

To prevent electromagnetic interference via the connecting cable, the sensor and separate electronic unit of the meter in the remote version should be located as close as possible to one another.

The maximum cable length depends on the conductivity of the measured liquid (see Fig. 3).

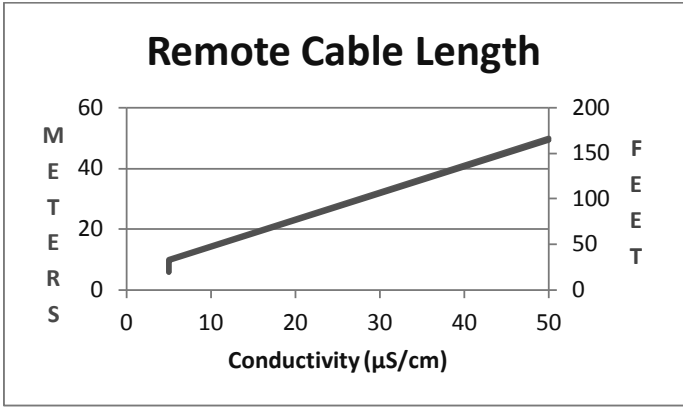

**Figure 3 - The maximum cable length**

#### 4.5. Dimensions of flanged sensor

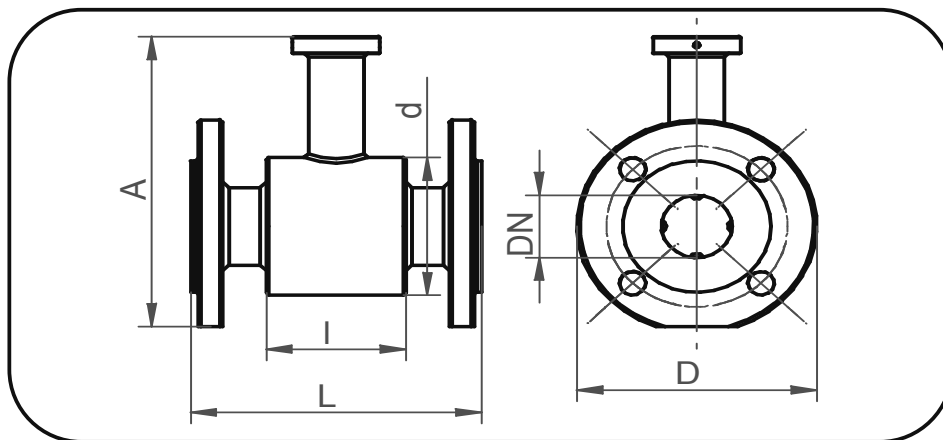

Figure 4 - Dimensions of flanged sensor

Sensor dimensions for various rated diameters (DN)  
Flanges according to standard ČSN EN 1092-1.

Table 2 - Sensor dimensions for various rated diameters (EN 1092-1)

	DN	D	d	A*	L	l	Weight [ kg ]**
PN 40	15	95	62	164	200	66	3
	20	105	62	170	200	66	3
	25	115	72	180	200	96	3
	32	140	82	199	200	96	4
	40	150	92	209	200	96	4
	50	165	107	223	200	96	6
PN 16	65	185	127	244	200	96	9
	80	200	142	260	200	96	14
	100	220	162	280	250	96	16
	125	250	192	310	250	126	19
	150	285	218	340	300	126	25
	200	340	274	398	350	211	41
PN 10	250	395	370	480	450	211	54
	300	445	420	535	500	320	77
	350	505	480	584	550	320	92
	400	565	530	642	600	320	116
	500	670	640	752	600	320	167
	600	780	760	870	600	320	315
PN 6	700	895	880	990	700	420	357
	800	975	960	1100	800	420	427

\* Dimension A (sensor height) is net of the electronic unit box (or terminal box in the remote meter version).

\*\* The sensor weight data is only approximate.

**Table 3 - Sensor dimensions for various rated diameters (ANSI B16.5)**

	<b>DN</b>	<b>D</b>	<b>d</b>	<b>A*</b>	<b>L</b>	<b>l</b>	<b>Wt. (lb.)**</b>
<b>ANSI</b> (max. working pressure 230 psi)	1/2"	3.5	2.4	6.8	7.9	2.6	7
	3/4"	3.88	2.4	7.0	7.9	2.6	7
	1"	4.25	2.8	7.4	7.9	3.8	7
	1 1/4"	4.63	3.2	7.8	7.9	3.8	9
	1 1/2"	5	3.6	8.2	7.9	3.8	9
	2"	6	4.2	8.9	7.9	3.8	13
	2 1/2"	7	5.0	9.8	7.9	3.8	20
	3"	7.5	5.6	10.4	7.9	3.8	31
	4"	9	6.4	11.5	9.8	3.8	35
	5"	10	7.6	12.6	9.8	5.0	42
	6"	11	8.6	13.6	11.8	5.0	55
<b>ANSI</b> (max. Working pressure 150 psi)	8"	13.5	10.8	15.9	13.8	8.3	90
	10"	16	14.6	19.1	17.7	8.3	119
	12"	19	16.5	21.6	19.7	12.6	170
	14"	21	18.9	23.8	21.7	12.6	203
	16"	23.5	20.9	26.0	23.6	12.6	256
<b>AWWA</b> (max working pressure 86 psi)	20"	27.5	25.2	30.2	23.6	12.6	368
	24"	32	29.9	34.8	23.6	12.6	694
	28"	36.5	34.0	39.1	27.6	16.5	794
	32"	37.5	37.7	43.5	31.5	16.5	941

\* Dimension A (sensor height) is net of the electronic unit box (or terminal box in the remote meter version).

\*\* The sensor weight data are only approximate.

#### 4.6. Dimensions of flangeless sensor

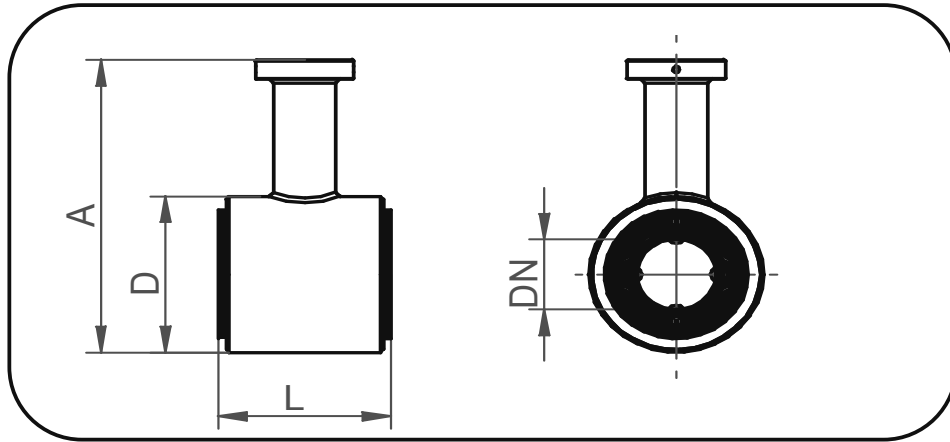

Figure 5 - Dimensions of flangeless sensor

#### Flangeless sensor dimensions for various rated diameters (DN)

Table 4 - Flangeless sensor dimensions for various rated diameters

Size (DN)	D	A*	L
3/4" (20)	2.4 (62)	5.7 (145)	2.9 (74)
1" (25)	2.8 (72)	6.2 (158)	4.1 (104)
1-1/4" (32)	3.2 (82)	6.6 (168)	4.1 (104)
1-1/2" (40)	3.6 (92)	7.0 (179)	4.1 (104)
2" (50)	4.2 (107)	7.6 (192)	4.1 (104)
2-1/2" (65)	5.0 (127)	8.3 (212)	4.1 (104)
3" (80)	5.6 (142)	8.9 (227)	4.1 (104)
4" (100)	6.4 (162)	9.7 (247)	4.1 (104)
5" (125)	7.6 (192)	10.9 (277)	5.3 (134)
6" (150)	8.6 (218)	11.9 (303)	5.3 (134)
8" (200)	10.8 (274)	14.1 (359)	8.6 (219)

\* Dimension A (sensor height) is net of the electronic unit box (or terminal box).

#### 4.7. Critical dimensions of transmitter

Transmitter height approx 5-7/8" (150 mm)

Transmitter length approx 8-1/8" (207 mm)

## 4.8. Specifications

**Table 5 - Flow sensor specifications**

<b>Performance</b>	
Range	0.33 – 32.8 ft/s (0.1 – 10 m/s)
Accuracy	0.3% of reading for 5 to 100% Qmax
Repeatability	0.15% of reading

<b>Transmitter</b>	
Power source	230 VAC (+10% / -15%) / 50/60 Hz 115 VAC (+10% / -15%) / 50/60 Hz 24 VDC (±15%)
Power consumption	AC = 10 VA; DC = 10 W
Housing material	Aluminium casting
Ambient temperature	-4°F (-20°C)* to 140°F (60°C)
Outputs	
Analog (active)	0/4-20 mA (isolated)
Pulse (passive)	24V, 60 mA (isolated)
Status (passive)	24V, 60 mA (isolated)
Communication	Keypad on display, HART with <i>PACTware</i>
Menu language	English, German
Protection class	IP 67
Empty pipe detection	At measuring electrodes, selectable on/off

\*Display may not read under this value but the outputs will still function

<b>Sensor</b>	
Sensor size	Flanged, ½" (DN15) to 32" (DN800) Wafer, ¾" (DN20) to 8" (DN200)
Pressure rating	ANSI B16.5 (150#) or EN 1092-1 Standard
Grounding	Grounding electrode provided for ¾" (DN20) and larger Optional grounding rings (304 SS)
Maximum operating temperature of liquid	302°F (150°C)* – liner dependent
Minimum conductivity of liquid	20 µS/cm; consult factory for down to 5 µS/cm
Lining	Hard rubber up to 176°F (80°C), size ¾"-32" (DN20-DN800) Soft rubber up to 176°F (80°C), size ¾"-32" (DN20-DN800) PTFE up to 302°F (150°C), size ½"-10" (DN15-DN250) ECTFE up to 266°F (130°C), size 12"-32" (DN300-DN800)
Measuring electrodes	316 Stainless Steel – standard with rubber liner Hastelloy C4 – standard with PTFE or ECTFE liner Other options available as a special
Pipe spool material	304 Stainless Steel
Sensor body and flanges	Carbon Steel standard; optional 304 SS flanges
Protection class	IP67 or IP68

\*For liquid temperatures greater than 212°F (100°C) use a remote transmitter

## **5. COMMISSIONING**

### **5.1 Installation of electromagnetic flow meters**

The meter installation work shall be performed in strict observance of the procedures and rules described in this manual.

To prevent undesirable interference, the power cables shall be laid at least 10 inches (25 cm) away from all signal cables. The signal cables include the cable connecting the sensor and the associated electronic unit (in the case of a remote meter version) and output signal cables. All cables shall be laid outside the thermal insulation layer on the piping (if any). Only shielded conductors shall be used to connect the output signals.

In applications where high levels of electromagnetic field interference at the measuring location can be expected (e.g. in the vicinity of power frequency converters), the remote meter version should be avoided. In these cases it is also recommended to include a filter in the power supply line to the electronic unit.

Filter specification: The filter is intended to suppress dissemination of the undesirable high frequency disturbances from the power supply cable to the flow meter system. Use any commercial filter of suitable parameters including protection class, and install it as close to the meter as possible. If need be, the filter can be placed in a special protection housing. When installing the filter, observe the applicable safety regulations.

Rated voltage:	250V/50Hz
Rated current:	0.5A and more
Suppression characteristic:	10kHz: 10 to 20dB 10MHz: 40dB

### **5.2 Piping**

No chemical injection or batching unit (such as chlorine compound injector) should be located at the input side of the sensor. The insufficient homogeneity of the flowing liquid may affect the flow-rate values indicated by the meter.

The meter performance will be the best if the liquid flow in the piping is well stabilized; therefore it is necessary to observe specific rules for the sensor placement in piping. In the contact planes between the sensor and the adjoining piping sections there should be no edges as these would cause flow turbulence. Make sure that 5 diameters of straight piping section is provided before and 3 diameters after the sensor; their required length is proportional to the inner diameter of the piping concerned.

If more than one flow-disturbing element such as pipe bend or fitting is located near the sensor, the required length of straight piping section on the sensor side concerned should be multiplied by the quantity of such elements.

In the cases of bi-directional flow-rate measurement, the same conditions concerning flow stability shall be met at the input and output sides of the sensor.

In the cases where the pipe size larger than that of the meter sensor, it is necessary to use conical reduction pieces with the angle of taper not exceeding 15°. In the cases of bi-directional flow measurement, the minimum length of straight piping sections on both sides is 5 DN. In horizontal sensor installations, to prevent bubbling, use concentrically-fitted reduction pieces (see standard ČSN EN ISO 6817).

Pipe narrowing sections with angles not exceeding 8° can be taken for straight sections.

In the cases where the liquid is pumped, the flow sensor shall always be placed at the output side of the pump. The required length of the straight piping section between the pump and sensor is at least 25 diameters.

The sensor shall be always placed before the closing valve in the piping.

The sensor can be fitted in the piping in either horizontally or vertically. However, make sure that the electrode axis is always horizontal and, if the sensor is mounted in a horizontal position, the flange section for attachment of the MA1 faces upwards.

In the cases where the sensor is mounted in a vertical position, the flow direction shall always be upwards.

To ensure correct meter function at all times, the measured liquid shall completely fill up the sensor and no air bubbles shall be permitted to accumulate or develop in the sensor tube. Therefore the sensor shall never be placed in the upper pocket of the piping or in a vertical piping section where the flow direction is downwards.

In piping systems where complete flooding of the piping cannot always be guaranteed, consider placing the sensor in a bottom pocket where full flooding is ensured.

If the sensor is located near a free discharge point, such point shall be by at least 2 diameters higher than the top part of the sensor.

Make sure that the adjoining piping is clamped/supported as close to the sensor as possible, to prevent vibrations and damage to the sensor.

In applications where continuous liquid flow is essential, a bypass shall be provided to allow for sensor servicing. A sensor bypass may also be a reasonable solution in the cases where, to dismantle the flow sensor from the piping, liquid from a very long piping section would have to be discharged.

**Figure 6 □ Single bend**

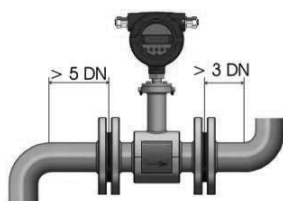

**Figure 7 - Reduction**

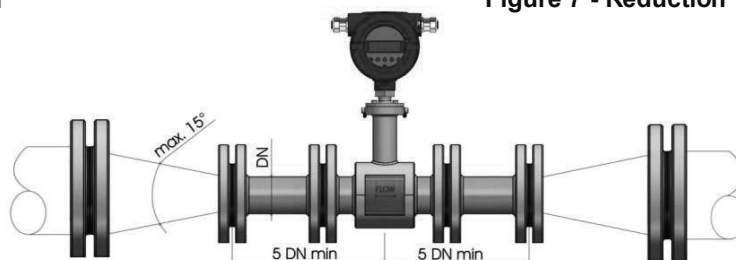

**Figure 8 □ Straight section**

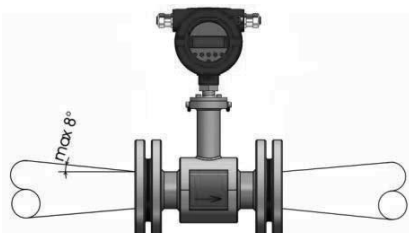

**Figure 9 □ 25 D's from output of pump**

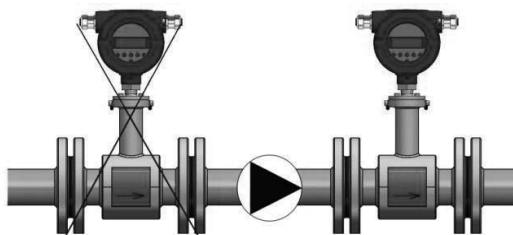

**Figure 11 □ Horizontal electrodes**



Figure 10 □ Install before control valve

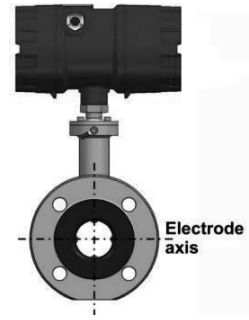
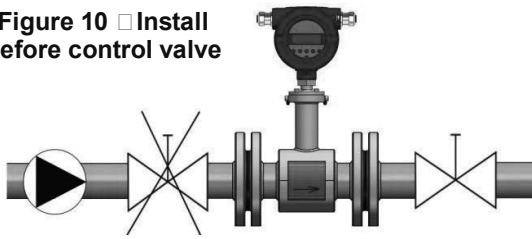

Figure 12 □ Vertical flow going up

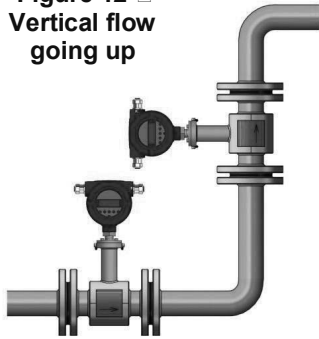

Figure 13 □ Flow directed up

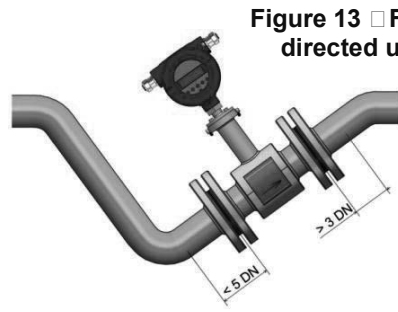

Figure 14 □ No upper pockets or flow going down in vertical section

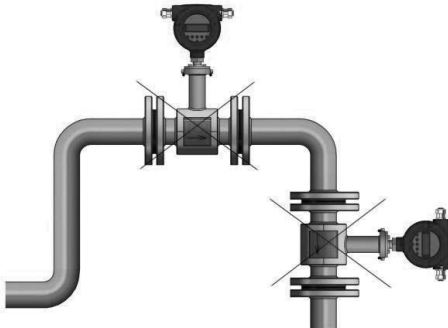

Figure 15 □ Discharge point

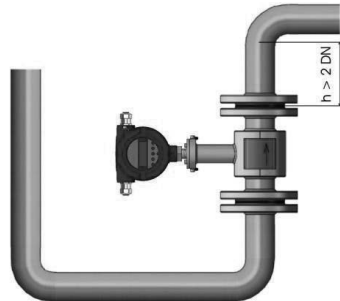

Figure 16 □ Prevent excess vibration

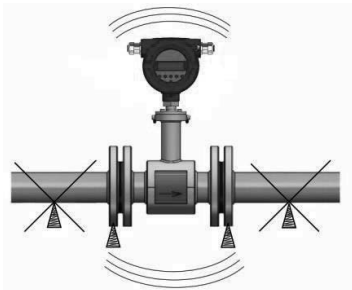
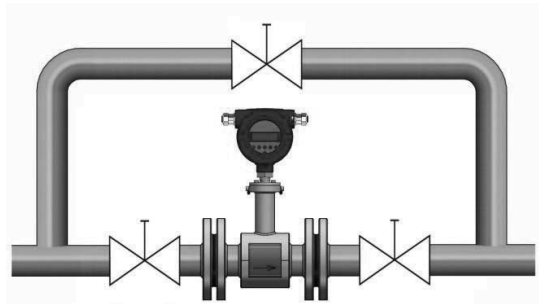

Figure 17 - Bypass



### 5.3 Earthing

Every sensor, with the exception of ½" (DN20), has a third grounding electrode provided at the base of the spool piece. Additional grounding is possible utilizing the blue grounding lugs on the neck of the sensor. A connection should be made to the electrically conductive piping (mating flanges) upstream and downstream of the sensor to the grounding lugs. Grounding rings can also be provided if the sensor is installed in non-conductive piping.

When using a remote transmitter, additional grounding is possible by connecting the grounding lug on the sensor to the external grounding on the remote transmitter housing using a copper conductor of cross-section 4mm<sup>2</sup>.

**Figure 18** □ Grounding the remote transmitter

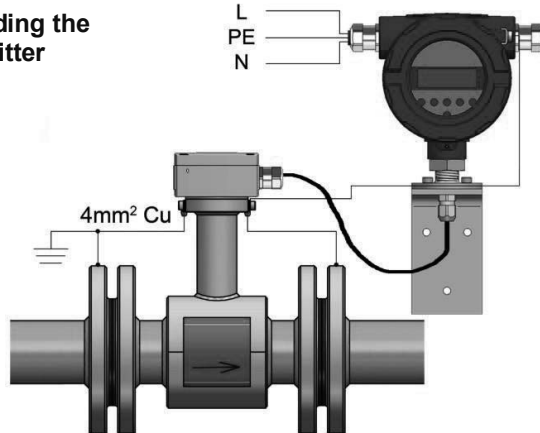

#### 5.3.1 Cathodic protective units

With a remote transmitter, ensure the transmitter is isolated from earth ground. Transmitter should be at same potential as sensor. Ground everything to the same ground as the cathodic protection.

	<p><b>Warning</b> According to EN 50178:1997 all electrical circuits with protective safety isolation without any protection against contacts must observe the following maximum voltages:</p> <ul style="list-style-type: none"><li>• Maximum AC voltage (root mean square value) 25 V</li><li>• Maximum DC voltage 60 V</li></ul> <p>Do not connect PE to any higher voltage!</p>
-------------------------------------------------------------------------------------	-----------------------------------------------------------------------------------------------------------------------------------------------------------------------------------------------------------------------------------------------------------------------------------------------------------------------------------------------------------------------------------------

#### 5.4 Remote transmitter with IP68 sensor.

The transmitter is supplied with a permanently attached connecting cable in protection class IP67. The other end of the connecting cable is loose. The customer connects the cable to the sensor terminal box itself.

Terminal box is equipped with a gland M20x1.5 and terminal board with WAGO terminals. The housing is capped with O - ring. In this case it is the sensor with IP67 protection.

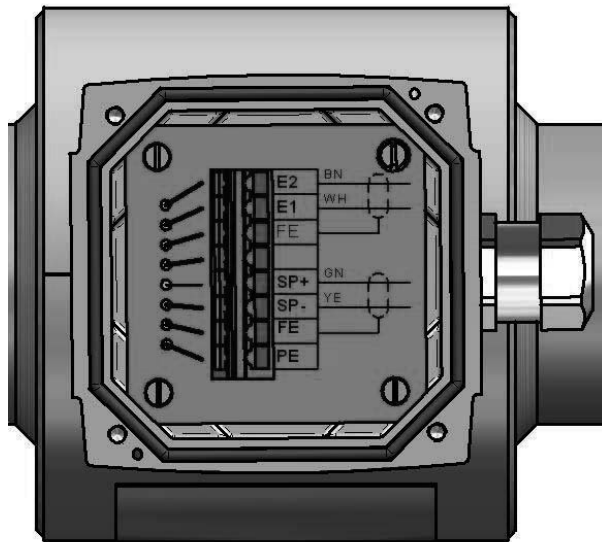

For a sensor with IP68 protection, the inside of the terminal box must be filled with supplied resin GHB1.

Potting compound GHB1 (250 ml) including the necessary accessories are included in delivery for remote version IP68.

The application resin procedure GHB1:

Remove the protective foil.

Mix the two components about 2 min.

Place the funnel.

Cut off the bag with the resin.

Pour the contents of the bag to the brim to the terminal box.

Curing time mixture is up to 150 minutes. Temperature during potting is +15°C to +30°C.

## **6. MA1 TRANSMITTER: MODE OF OPERATION AND CONFIGURATION**

### ***6.1 System design***

The meter consists of a sensor and a MA1 transmitter. The device can be used to perform measurements with any liquid, conductive media, providing that the sensor's material is suitable for the product being used.

The MA1 transmitter generates the inductive current necessary for the magnetic field and preprocesses the induced voltage at the electrodes.

#### **6.1.1 Data memory chip DSM**

The replaceable data memory chip (DSM) is an EEPROM device in a DIL-8 housing, located in a socket on the power supply board. It contains all characteristic data of the sensor e.g. sensor constant, version or serial number. Consequently, the memory module is linked to the sensor and in case of a transmitter replacement it has to remain by the sensor!

After replacing the transmitter or its electronics, the DSM will be installed in the new transmitter. After the measuring system has been started, the measuring point will continue working with the characteristic values stored in the DSM. Thus, the DSM offers maximum safety and high comfort when exchanging device components.

Power supply board MA1

Slot DSM

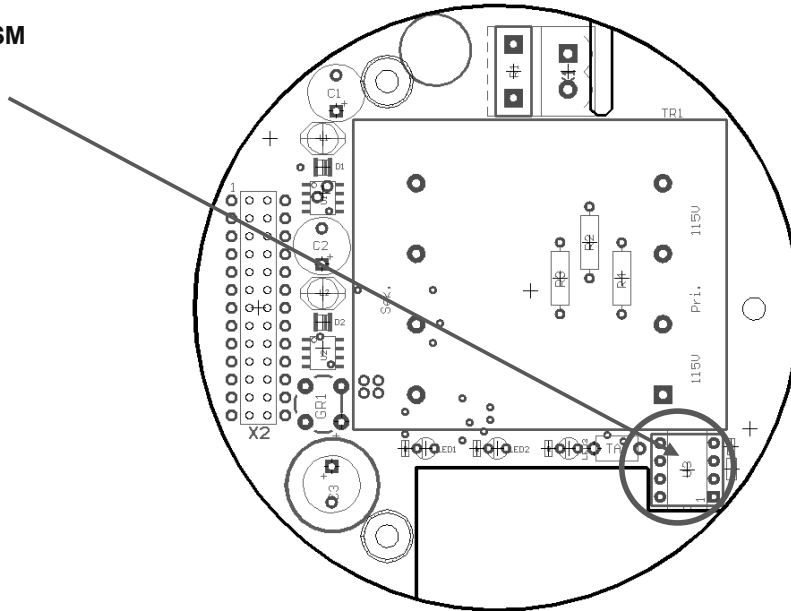

**Figure 19 - Power supply board MA1**

At any exchange watch the polarity of the memory chip. Pin 1 is signed by a dot or a notch.

### **6.1.2 Safety of operation**

A comprehensive self-monitoring system ensures maximum safety of operation.

- Potential errors can be reported immediately via the configurable status output. The corresponding error messages will also be displayed on the transmitter display. A failure of the auxiliary power can also be detected via the status output.
- When the auxiliary power fails, all data of the measuring system will remain in the DSM (without back-up battery).
- All outputs are electrically isolated from the auxiliary power, the sensor circuit and from each other.

## **7. OUTPUT**

### **7.1 Output signal**

All signal outputs:

Electrically isolated from each other and from ground.

Analog output:

0/4-20mA current output, electrically isolated, optional with HART<sup>®</sup> for *PACTware*.  
(Using the HART<sup>®</sup>-protocol the current output has to be assigned to volume flow in the mode of 4-20mA – Contact the factory to download the DTM)

Pulse output:

Pulse width; default value 50 ms  
Pulse width adjustable range is 0.5 ... 2000 ms  
50% duty cycle

When programming the pulse duration, a plausibility check is carried out. If the selected pulse duration is too long for the set upper range value, an error message will be displayed.

$f_{\max} = 1 \text{ kHz}$

passive via optocoupler

$U = 24 \text{ V}$

$U_{\max} = 30 \text{ V}$

$I_{\max} = 60 \text{ mA}$

$P_{\max} = 1.8 \text{ W}$

Pulse value:

1 pulse/unit

The pulse value can be multiplied by a factor between 0.001 - 100.0 (decade increments) of the selected pulse unit (e.g. m<sup>3</sup>)

Status output:

for: forward and reverse flow, MIN flow rate, MAX flow rate or alarm,

passive via optocoupler

$U = 24 \text{ V}$

$U_{\max} = 30 \text{ V}$

$I_{\max} = 60 \text{ mA}$

$P_{\max} = 1.8 \text{ W}$

### **7.2 Failure signal**

A failure in the meter can be indicated via the current output or the status output. The current output can be set to a failure signal (alarm) of  $I < 3.8 \text{ mA}$  or  $I > 22 \text{ mA}$ .

The status output can be configured as make or break contact.

### **7.3 Load of the current output**

Standard version:  $\leq 600 \text{ Ohm}$   
HART<sup>®</sup> minimum load  $> 250 \text{ Ohm}$

## **7.4 Damping**

Programmable from 0 to 60 seconds.

## **7.5 Low flow cut-off**

The low-flow cut-off can be set to values between 0 and 20% using the software. The set value refers to the upper range value. If the measured value is lower than the set volume, the flow rate will set to 0.0. This results in the analog output being set to 0/4 mA, and the pulse output will stop generating pulses.

The configurable hysteresis takes effect in only one side while exceeding this limit.

# **8. MA1 PERFORMANCE CHARACTERISTICS**

## **8.1 Reference conditions**

In conformity with IEC 770: temperature: 20° C, relative humidity: 65%, air pressure: 101.3 kPa

## **8.2 Measuring tolerance**

See characteristic values of the corresponding sensor.

## **8.3 Repeatability**

See characteristic values of the corresponding sensor.

## **8.4 Influence of ambient temperature**



For the pulse output:            $\pm 0.05$  % per 10 K.  
For the current output:          $\pm 0.1$  % per 10 K.

## **9. MA1 OPERATING CONDITIONS**

### **9.1 Environmental conditions**

#### **9.1.1 Degree of protection**

MA1 standard housing is IP67.

	<p><b><u>Caution:</u></b> Ingress protection IP 68 is only achieved if this particular model is selected with remote electronics.</p>
	<p><b><u>Danger:</u></b> Particular care must be taken if the window in the housing becomes fogged over or discolored because moisture, water or product might seep through the wire sheath into the terminal compartment in the housing.</p>
	<p><b><u>Warning</u></b> Electromagnetic compatibility is only achieved if the electronics housing is closed. Leaving the enclosure open can lead to electromagnetic disturbances.</p>

### **9.2 Process conditions**

#### **9.2.1 Fluid temperature**

The data sheet/rating plate of the connected transmitter must be observed. With directly mounted transmitter on the sensor the heat entry must be considered from the process to the transmitter.

#### **9.2.2 State of aggregation**

Liquid.

#### **9.2.3 Viscosity**

No restrictions.

The data sheet/rating plate of the connected transmitter must be observed.

#### **9.2.4 Fluid temperature limit**

The data sheet/rating plate of the connected transmitter must be observed.

#### **9.2.5 Flow rate limit**

The data sheet/rating plate of the connected transmitter must be observed.

#### **9.2.6 Pressure loss**

The data sheet/rating plate of the connected transmitter must be observed.

### 9.2.7 Empty pipe detection

Transmitters have an on and off switch for empty pipe detection. The operating reliability depends on the conductivity of the liquid medium and the cleanliness of the electrodes.

## 10. MA1 Electrical Connections

Mains	230 V AC 115 V AC; or 24 V DC	+10%, -15% +10%, -15%;  ±15 %	50/60 Hz 50/60 Hz
Power input	10 VA (VAC); 10W (VDC)		

### 10.1 Electrical connections

Table 6 - Process terminals

Process terminals			
Terminal	Label	Polarity	Function
1	PE		Protective conductor
2	N		Mains
3	L		Mains
4	Pulse	-	Pulse output (passive)
5	Pulse	+	Pulse output (passive)
6	Status	-	Status output (passive)
7	Status	+	Status output (passive)
8	Current Out.	-	Current output (active)
9	Current Out.	+	Current output (active)

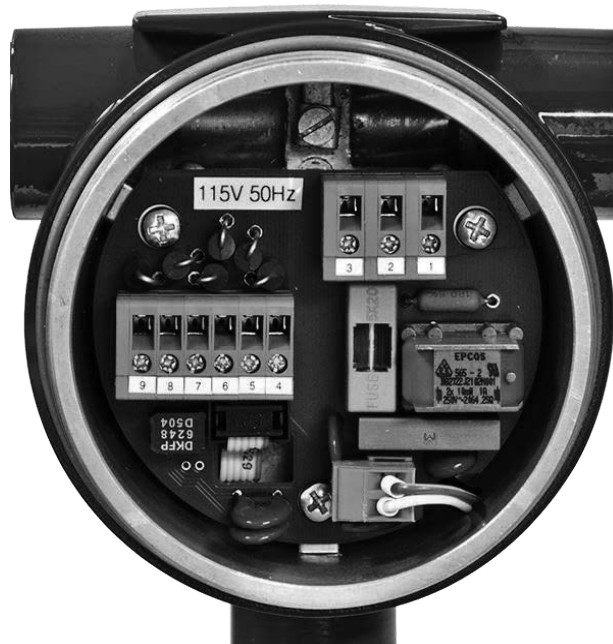



## HART® connection

A number of options are available for HART® communication. The HART®- Interface is connected via terminals 8 and 9 of the active current output. The minimum load resistance must be 250Ω. HART communication is used with *PACTware*. Please contact the factory for the DTM.

### Installing DTM (*PACTware*)

Contact MAGNETROL for DTM file and then proceed with the following instructions:

1. Read the file ReadMe.txt and run the setup.exe file. Please follow the instructions of the installer and the ReadMe.txt file.
2. When installation is complete please run the software *PACTware*, display Device Catalog (for example pressing F3) and perform the update by pressing Update device catalog. In the catalog will be added device "UMF Durchfluss-Messumformer HART" company Heinrichs Messtechnik GmbH.
3. Connect the flow meter to computer on which is running the software *PACTware* (via Hart probe or HART card in the computer).
4. You can begin to communicate with flow meter using *PACTware*.

## 10.2 Remote version

Table 7 □ Sensor terminals

Sensor terminals			
Terminal	Label	Polarity	Function
1	FE		Screen field coil
2	SP -	-	Field coil
3	SP +	+	Field coil
4	FE		Shield / Functional ground
5	E1		Electrode 1
6	E2		Electrode 2

The outer shield has to be connected to the metalized cable glands at both ends. The inner shields are connected to each other and are plugged into the terminal labeled "Schirm / shield".

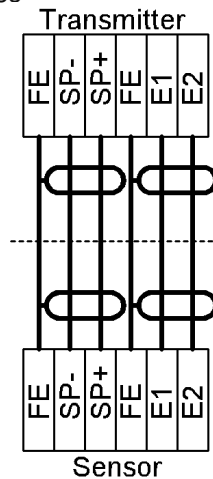

Fig. 20 □ Transmitter



Caution:

Do not connect or disconnect the field coil cable before the primary power of the meter has been disconnected!

If the transmitter is mounted separately from the sensor, the following cables must be used:

Electrode cable and field coil cable as shielded twisted pair. In order to protect the cable from external interference, the twisted-pair wires are covered by an additional, overall shield e.g. PAARTRONIC CY-CY-LiYCY (TP) 2x2x0.25mm<sup>2</sup> (UNITRONIC CYPiDY (TP) 2x2x0.25mm<sup>2</sup>).

At cable length more than 10m a wire cross section of at least 0,5mm<sup>2</sup> is required e.g. PAARTRONIC CY-CY-LiYCY (TP) 2x2x0.5mm<sup>2</sup>.

The outer shield is grounded by means of special EMC-compliant cable glands at both ends of the cable.

**Connecting the cable shield in the cable gland:**

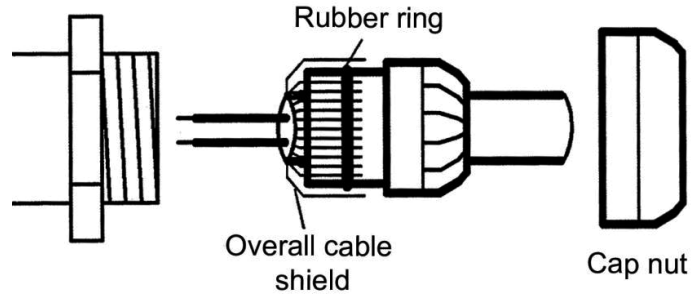

## **11. MAINTENANCE AND REPAIR**

The MA1 meter is designed as maintenance-free performance. It contains no parts which have to be replaced or adjusted cyclically.

While commissioning or maintenance, mains power must be switched off. Do not connect or disconnect the wirings between sensor and transmitter while power is on.

The transmitter electronics may be exchanged only as a complete module. A completely new transmitter may also be purchased.

### ***11.1 Replacing the transmitter***

The transmitter can be replaced in the field without effecting the calibration of the flow meter when the DSM chip is also replaced.

- 1) Remove current transmitter by unscrewing the four screws on the sensor neck and exposing the sensor wiring.
- 2) Unplug the sensor from the current transmitter.
- 3) Remove the DSM chip (refer to section 6.1) from the power board. To get to the power board, remove the faceplate and display module.
- 4) Plug the current DSM chip into the new transmitter on the power board. The same procedure can be used as was completed on the removal of the DSM chip.
- 5) Connect the transmitter wiring to the current sensor, similar to step 2.
- 6) Screw on the new transmitter to the current sensor.
- 7) Transmitter is now operational with the same settings as original calibration.

## **12. MA1 Menu Structure**

### **12.1 Introduction**

The MA1 unit can be operated depending on equipment by using the keyboard or via *PACTware* using HART protocol.

In the following, transmitter operation and parameterization using the keyboard are described. The keyboard is located in the electronic compartment and covered by an inspection window.



**Figure 21 - MA1 Transmitter with keyboard**

### **12.2 Display**

The display has an integrated back lit, alphanumeric display with two 16-character lines. Measurement data and settings can be read directly from this display.

The LCD display is designed to be operated at temperatures ranging from  $-4^{\circ}\text{F}$  to  $+140^{\circ}\text{F}$  ( $-20^{\circ}\text{C}$  to  $+60^{\circ}\text{C}$ ) without incurring any damage. However, at freezing or near-freezing temperatures, the display becomes slow and readability of the measured values is reduced. At temperatures below  $+14^{\circ}\text{F}$  ( $-10^{\circ}\text{C}$ ), only static values (parameter settings) can be displayed. At temperatures exceeding  $140^{\circ}\text{F}$  ( $60^{\circ}\text{C}$ ), contrast decreases substantially on the LCD and the liquid crystals can dry out.

### **12.3 Operating modes**

The MA1 can be operated in the following modes:

1. Display mode: In display mode, measured values can be displayed in various combinations and settings can also be displayed. Parameter settings cannot be changed in this mode. Display mode is the standard (default) operating mode when the device is switched on.
2. Programming mode: In programming mode, parameters can be redefined. After entering the correct password, changes that are permissible for the customer (customer password) or all functions (service password for technicians) can be realized.  
NOTE – If password is manually changed it must be saved!  
If the customer password is lost the manufacturer cannot retrieve it without returning the unit.

## 12.4 Operation

### 12.4.1 Operation interface

**Functional classes** are displayed as headings beneath which displays and parameters are shown in logical groups.

Beneath this is the **menu level**, which lists all measured value displays or the headings for their underlying parameters (**parameter level**).

All functional classes are interlinked horizontally, while all sub points that are assigned to a functional class are displayed beneath the relevant class.

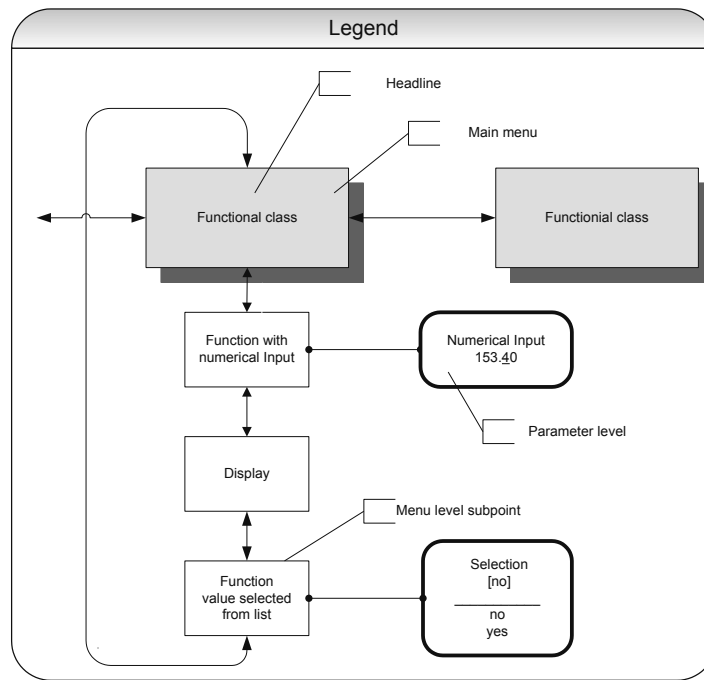

Figure 22 - Operation interface

### 12.4.2 The keys and their functions

There are six keys to change the settings.



#### Caution

Do not press these keys with sharp or sharp-edged objects such as pencils or screwdrivers!

Cursor keys: Using the cursor keys, the operator can change numerical values, give YES/NO answers and select parameters. Each key is assigned a symbol in the following table:

Table 8 □ Cursor keys

Descriptor	Symbol
Cursor key, arrow to the right	▶
Cursor key, arrow to the left	◀
Cursor key, arrow to the top	▲
Cursor key, arrow to the bottom	▼

Esc key: **The  $\square$ Esc $\square$  key allows you to cancel the current action.** Pressing Esc moves you to the next higher level where the operator can repeat the action. Pressing Esc twice moves you directly to the MEASURED VALUES functional class.

ENTER key: Pressing  $\downarrow$  (ENTER key) moves you from the menu level to the parameter level.  
**You confirm all entries with the  $\downarrow$  key.**

### 12.4.3 Functional classes, functions and parameters

Functional classes are written in all upper case letters (headings). The functions beneath each functional class are written in upper and lower case.

The various functional classes and functions are describes in Section 13. MA1 FUNCTIONS.

The lower line contains the following elements:

- Informational texts
- YES/NO answers
- Alternative values
- Numerical values (with dimensions, if applicable)
- Error messages.

If the user attempts to modify values for any of these parameters without entering the required password, the message "Access denied" will be displayed.

#### 12.4.3.1 Selection window / make a selection

In the selection window, the first line of the LCD always contains the heading, while the second line displays the current setting. This setting is shown in square brackets if the system is in Programming mode.

Function name
[Selection]

In Programming mode the operator can navigate to the desired setting by using the  $\blacktriangle$  key or the  $\blacktriangledown$  key and the operator can then confirm selection by pressing  $\downarrow$  (ENTER key). To retain the current setting, press Esc.

#### 12.4.3.2 Input window / modify a value

In the input window, the first line of the LCD always shows the heading, while the second line shows the current setting.

Example:

Function name
-4,567 Unit

These modifications can only be made in Programming mode, which means that a correct password must be entered. To move the cursor from one decimal place to the next, use the  $\blacktriangleleft$  or  $\blacktriangleright$  keys. To increase the value of the decimal place just under the cursor by "1," use the  $\blacktriangle$  key, and use  $\blacktriangledown$  key to lower the number by 1. To change the minus and plus sign, place the cursor in front of the first digit. To confirm and apply the change, press  $\downarrow$ . To retain the current value, press Esc.

#### 12.4.3.3 Passwords

Programming mode is password protected. The customer password allows all changes to be made that are permissible for customers. This password can be changed when the device is first put into operation. Such changes should be kept in a safe place. **If password is changed and lost, the factory cannot find the lost password and the unit will have to be returned to reset.**

The MA1 customer password in the device when delivered is 0002.

For further information on customer passwords, see Section 13.2 PASSWORD functional class.13.  
MA1 FUNCTIONS

The software functions of the transmitter are divided into functional classes, are arrayed in a circle and can be navigated by using the ◀ or ▶ cursor keys. To go back to your starting point (the MEASURED VALUES functional class) press Esc.

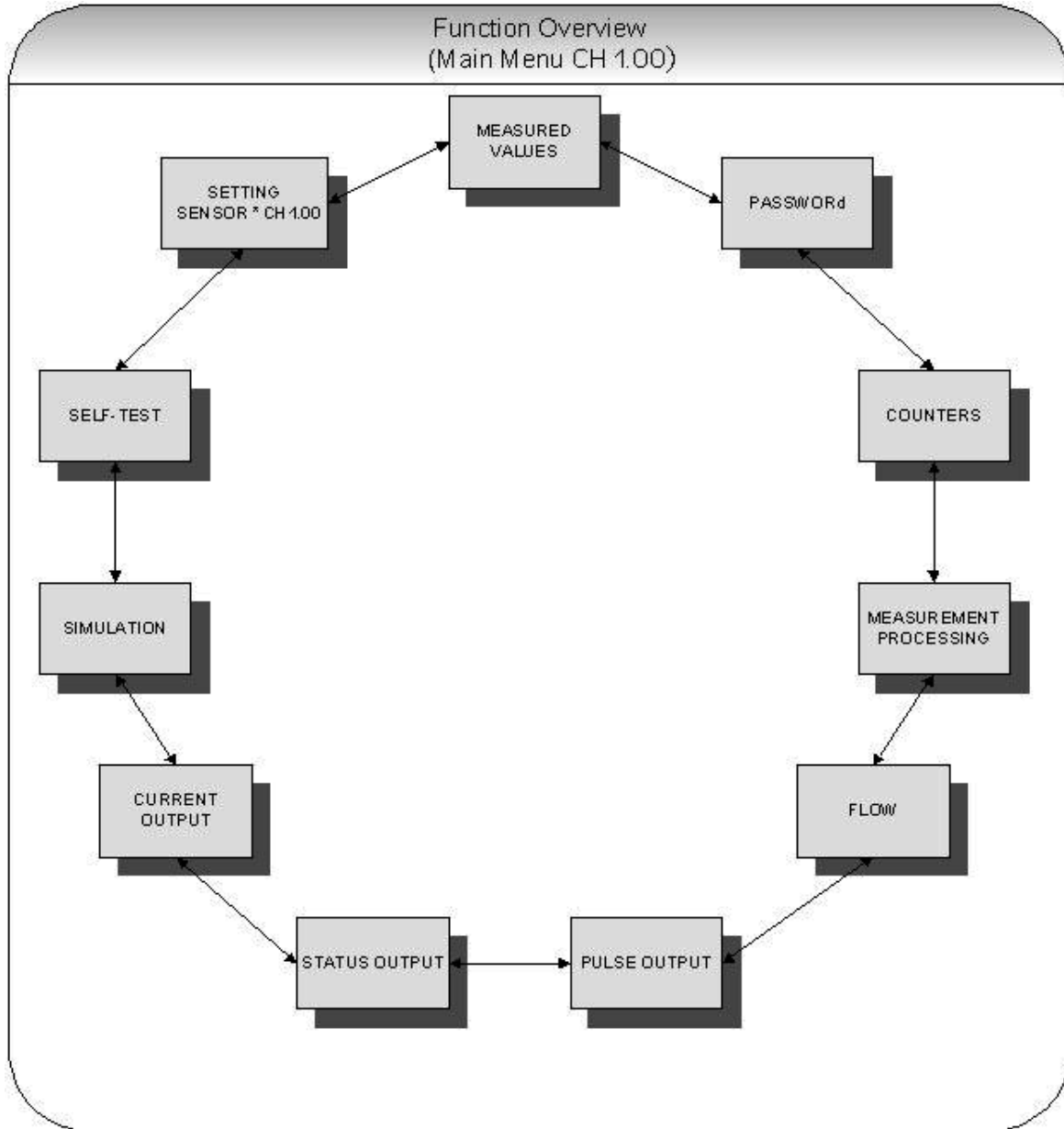

**Figure 23** □ MA1 FUNCTIONS

In the following, all software functions that can be accessed using the customer password are described. Functions that are only accessible to the vendor (service functions) are not described in the present document.

### 13.1 MEASURED VALUES functional class

The MEASURED VALUES functional class contains all functions for displaying the measured values.

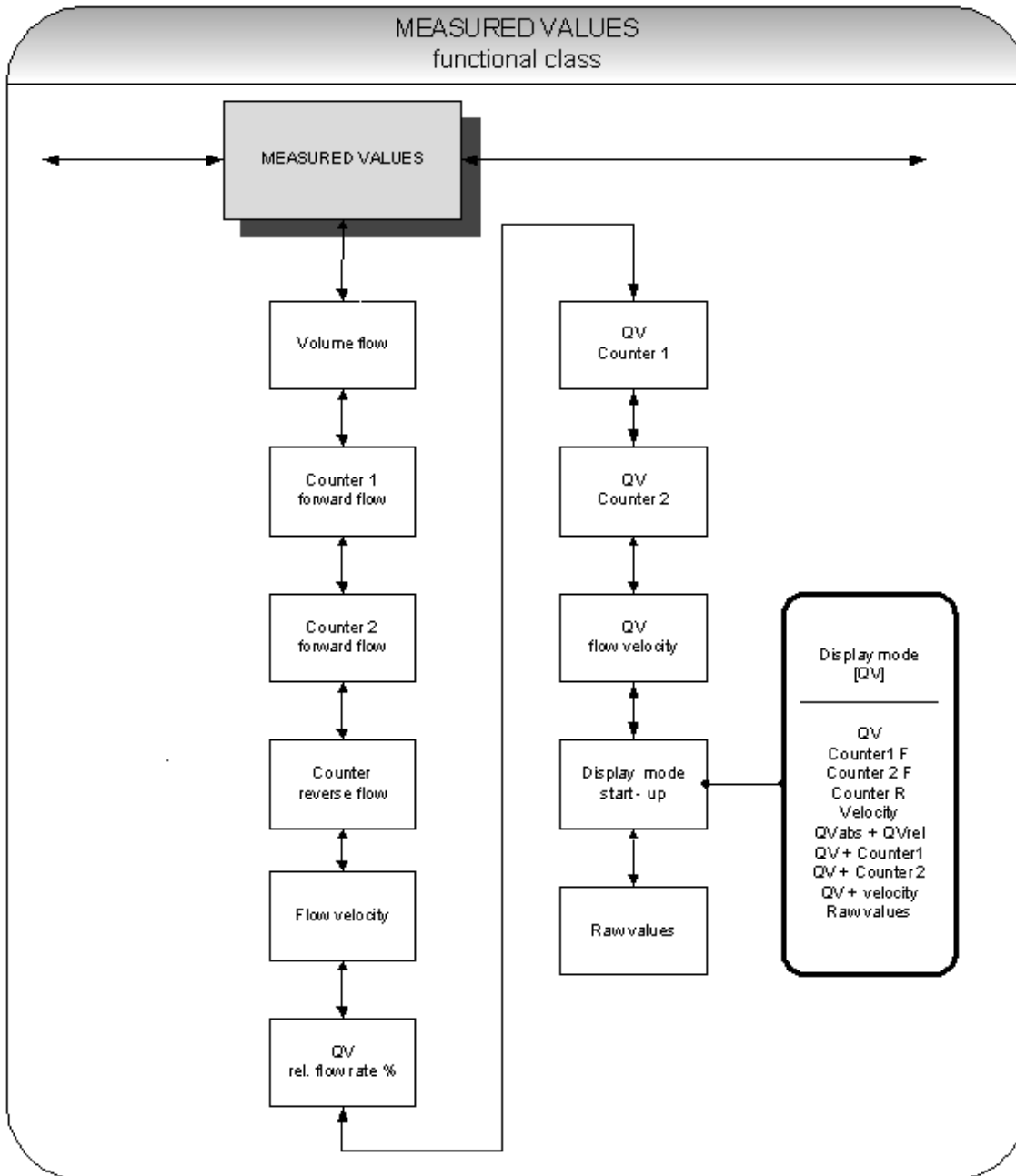

Figure 24 □ MEASURED VALUES functional class

### 13.1.1 Volume flow rate

If you select the function “volume flow,” the following will be displayed (example):

Volume flow 100.0 l/h
--------------------------

The LCD shows the current volume flow rate. You define the display unit in the functional class FLOW using the function “volume flow unit”.

### 13.1.2 Forward flow counter 1

Forward flow counter 1 and forward flow counter 2 are independent counters that can also be reset separately. With counter 1, for example, you can measure the yearly or monthly volume. If you select the function “forward flow counter 1”, the following will be displayed (example):

Counter 1 forw. + 000001.0 l
---------------------------------

The LCD shows the current value of forward flow counter 1. You define the display unit in the functional class COUNTERS using the function “unit of counter”.

### 13.1.3 Forward flow counter 2

The function is identical with the function of forward flow counter 1. For example, forward flow counter 2 can be used as a daily counter. If you select the function “forward flow counter 2”, the following will be displayed (example):

Counter 2 forw. + 000001.0 l
---------------------------------

The LCD shows the current value of forward flow counter 2. You define the display unit in the functional class COUNTERS using the function “unit of counter”.

### 13.1.4 Reverse flow counter

If you select the function “reverse flow counter”, the following will be displayed (example):

Counter reverse 000000.0 l
-------------------------------

The LCD shows the current value of the reverse flow counter. You define the display unit in the functional class COUNTERS using the function “unit of counter”.

### 13.1.5 Flow velocity

If you select the function “flow velocity,” the following will be displayed (example):

flow velocity 1.5 m/s
--------------------------

The LCD shows the current value of the mean flow velocity of the medium. The display unit is always meters per second (m/s).

### 13.1.6 Relative flow rate

The relative flow rate is the percentage ratio of the (current) volume flow and the entered upper range value of the volume flow. You set this upper range value in the functional class FLOW using the function “volume flow QV URV.”



The calculation of the relative flow rate is based on the following formula:

$$\text{Relative flow rate} = 100\% \times (\text{Qabs} - \text{lower range limit}) / (\text{upper range limit} - \text{lower range limit})$$

If you select the function "relative flow," the following will be displayed (example):

Relative flow 95.3%
------------------------

### 13.1.7 QV + Forward flow counter

If the function "QV+ forward flow counter 1" is selected, in the first line the content of the forward flow counter 1 will be displayed:

XXX.X l XXX.XX l/h
-----------------------

In the second line the LCD shows the current value of the actual volume flow of the medium. The displayed unit is defined in the functional class FLOW using the function "volume flow unit". The unit of the counter is defined in the functional class COUNTER using the function "counter unit".

### 13.1.8 QV + Forward flow counter 2

If the function "QV+ forward flow counter 2" is selected, in the first line the content of the forward flow counter 2 will be displayed:

XXX.X l XXX.XX l/h
-----------------------

In the second line the LCD shows the current value of the actual volume flow of the medium. The displayed unit is defined in the functional class FLOW using the function "volume flow unit". The unit of the counter is defined in the functional class COUNTER using the function "counter unit".

### 13.1.9 QV + flow velocity

If the function "QV + flow velocity" is selected, the following will be displayed:

XXX.X l/h XXX.X m/s
------------------------

In the first line of the LCD display the current value of volume flow and in the second line the flow velocity of the medium. The displayed volume flow unit is defined in the functional class FLOW using the function "volume flow unit", the unit of the medium's velocity is always m/s.

### 13.1.10 Display mode during startup

By choosing the *Display mode during startup* function the operator can define the default display. After the operator switched the device on and did not touch any keys for a longer period of time, the defined default display will be shown.

Display mode [QV]
----------------------

According to the description in Section 12.4.3.1 Selection window / make a selection, one of the following default displays can be selected.

- QV (volume flow rate),
- Counter 1 forward flow,
- Counter 2 forward flow,
- Counter reverse flow,
  - Velocity,
  - QVabs + QVrel,
  - QV + counter 1,
  - QV + counter 2,
  - QV + velocity,
  - and raw values.

### 13.1.11 Raw values

The “Raw value display” supports fault diagnostics and trouble shooting. Please inform our service department about the clear text error messages and contents of the “Raw value display”.

xxx.xxx	ggooo
iiii	gguuu

The displayed values are decimals and have the following meaning:

- xxx.xxx: Is a gauge for the measured electrode voltage.
- ggooo: Is a gauge for the upper value of the reference calibration.
- iiii: Is a gauge for the current to generate the field coil's magnetic field.
- gguuu: Is a gauge for the lower value of the reference calibration.

## 13.2 PASSWORD functional class

The PASSWORD functional class is comprised of the functions for entering and changing the customer password and entering the service password. To cancel the current action, press Esc.

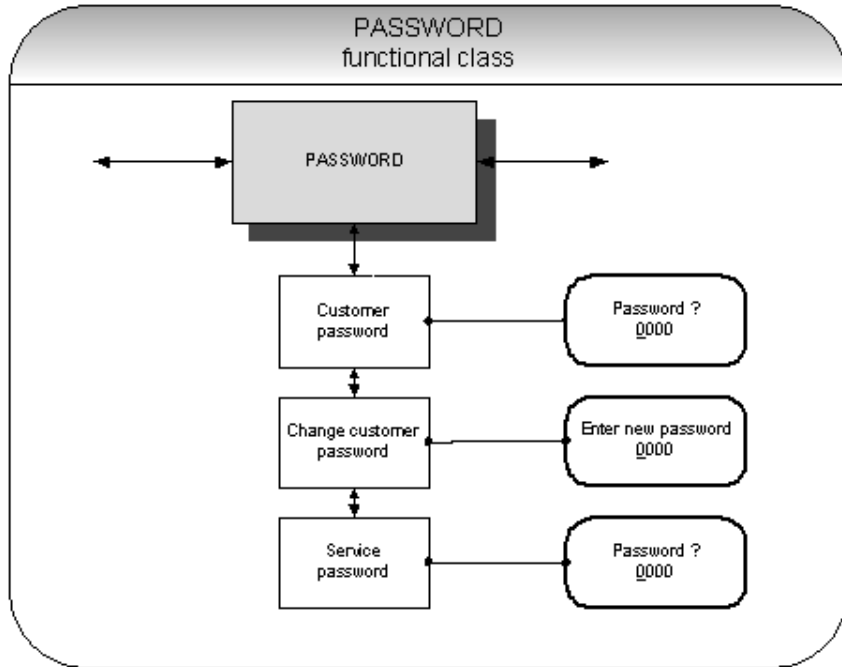

Figure 25 - PASSWORD functional class

### 13.2.1 Customer-password

After selecting the *Customer password* function and pressing ↵, the following will be displayed:

```
Password?  
 0000
```

According to the description in Section 12.4.3.2 Input window / modify a value/", the password can be changed. If the entered password is correct, the following message will be displayed

```
Password  
valid
```

If the entered password is not correct, the following message will be displayed

```
Password  
invalid
```

The customer password in the device when delivered is **0002**.

A valid customer password allows all software parameter changes to be made that are permissible for customers. After the operator switched the device off or did not touch any keys for about 15 minutes, the authorization to change settings related to password entry will automatically be canceled. If the operator does not enter a valid password, all settings can be displayed but not

changed. Parameter changes via HART may be carried out any time without entering password through the use of PACTware.

### 13.2.2 Change customer password

After entering a valid customer password, you may change the existing password and enter a new one. After selecting the *Change customer password* function and pressing ↵, the following will be displayed.

Enter New password _000
----------------------------

According to the description in Section “12.4.3.2 Input window / modify a value” the current value can be changed.

Press ↵ to confirm and save the new password. Make sure that you entered the desired password!

**A copy of the password should be kept in a safe place. If password is lost the complete unit will need to be returned to the factory and is not under warranty.**

### 13.2.3 Service password

You do not need the service password for setting the functions necessary for operation.

The service password is reserved for service technicians and not provided to customers. Correct settings are essential for proper operation of the device (e.g. parameterization and calibration values).

### 13.3 Counter functional class

The COUNTERS functional class is comprised of the following functions:

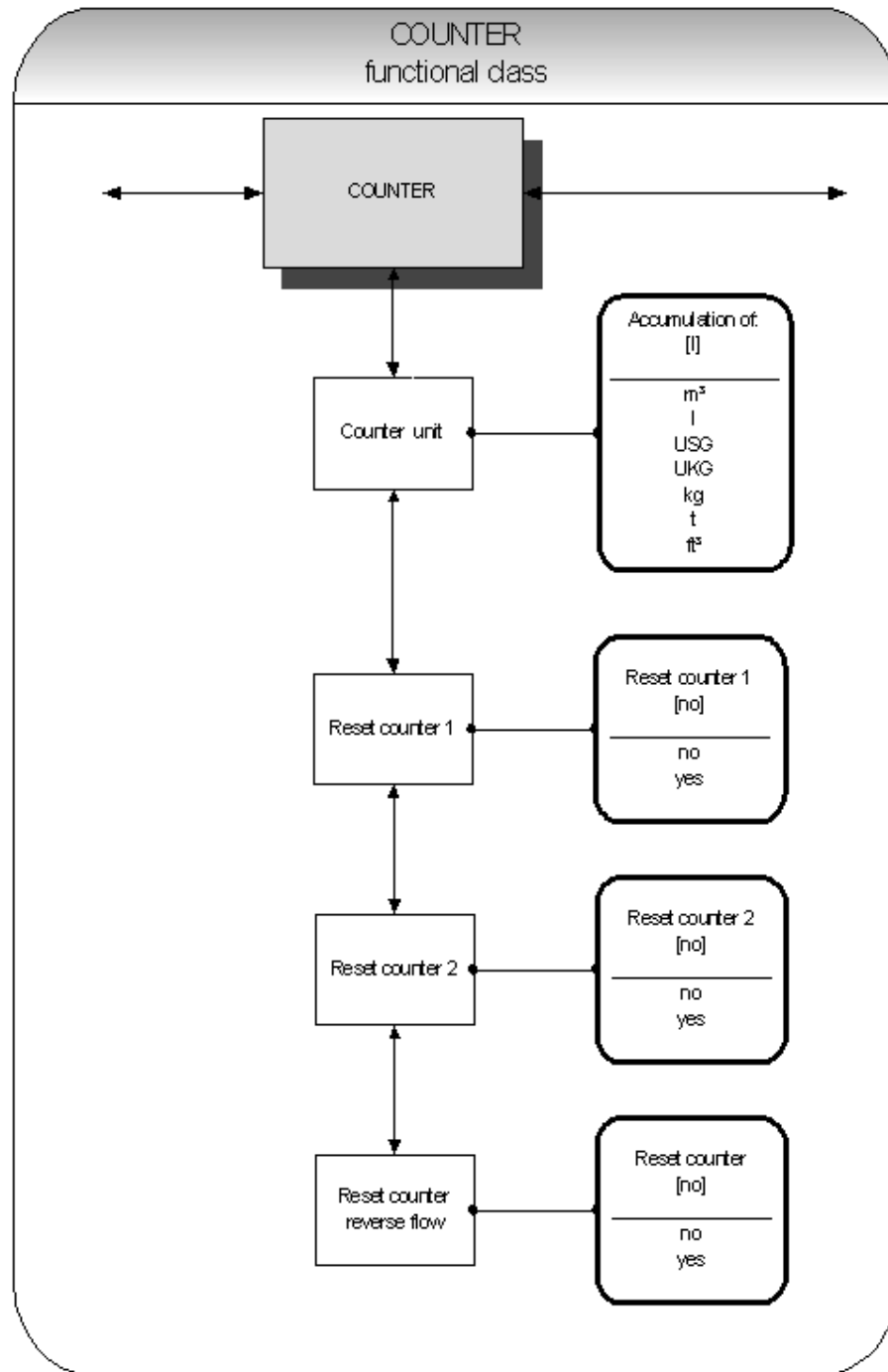

**Figure 26 - Counter functional class**

To change the current settings, enter the customer password. Otherwise, the settings can only be displayed but not changed. To cancel the current action, press Esc.

### 13.3.1 Unit of counters

After choosing the *Unit of counters* function and pressing ↵, the current forward and reverse counter unit will be displayed:

Accumulation of: [kg]
--------------------------

According to the description in Section “12.4.3.1 Selection window / make a selection”, one of the following units can be selected.

- Volume units: m<sup>3</sup> and l, as well as USG, UKG, ft<sup>3</sup> or
- Mass units: kg and t.

**When the unit is changed, the counters will be reset to 0.00 automatically.**

When using mass units the density must be configured for the density of the liquid.

### 13.3.2 Reset counter

The MA1 has 3 independent totalizing counters. Counter 1 and Counter 2 for forward flow and a reverse flow counter. Each of them can be reset individually on the initial value 0.00.

To reset one of the totalizing counters, you definitely need to toggle to [yes].

Reset counter [no]
-----------------------

According to the description in Section “12.4.3.1 Selection window / make a selection”, “yes” or “no” can be selected. By pressing Esc or toggling to [no] the operator can cancel the current action without changing the counter readings.

### 13.4 MEASUREMENT PROCESSING functional class

The MEASUREMENT PROCESSING functional class is comprised of all functions that affect the processing of the measured values.

To change the current settings, enter the customer password. Otherwise, the settings can only be displayed but not changed. To cancel the current action, press Esc.

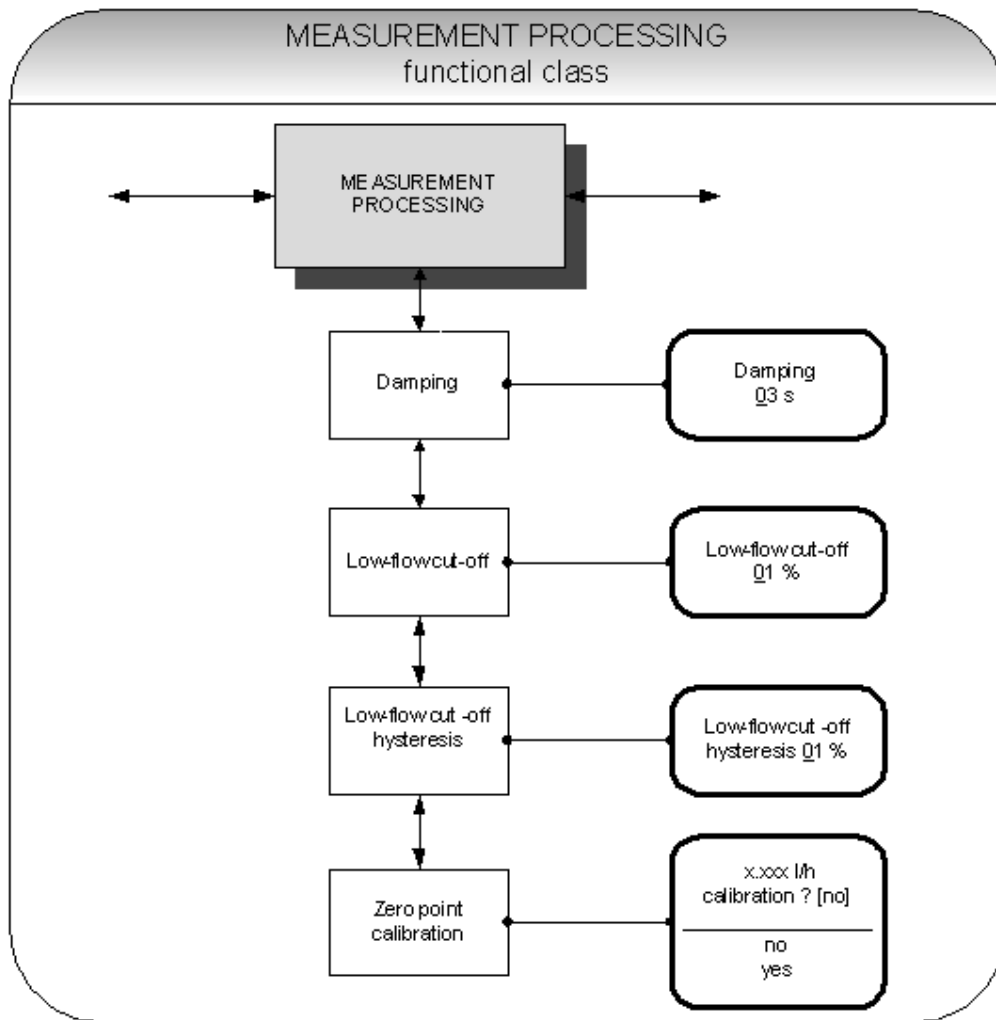

Figure 27 □ Measurement processing functional class

### 13.4.1 Damping

The damping value is intended to dampen abrupt flow rate changes or disturbances. It affects the measured value display and the current and pulse outputs. It can be set in intervals of 1 second from 1 to 60 seconds. After choosing the *Damping value* function and pressing ↵, the following selection field will be displayed:

Damping <u>0</u> 3 s
-------------------------

The current damping value will be displayed. According to the description in Section “12.4.3.2 Input window / modify a value”, the current value can be changed. After setting the new damping value, press ↵ to confirm your entry.

### 13.4.2 Low flow cut-off

The value for low flow cut-off (low flow volume) is a limiting value stated as a percentage that relates to the upper-range value of the flow rate. If the volume drops below this value (e.g. leakage), the displayed value and the current outputs will be set to “ZERO.” The value for low flow cut-off can be set from 0 to 20 % in 1-percent increments. After choosing the *Low flow cut-off* function and pressing ↵, the following selection field will be displayed:

Low flow cut-off <u>0</u> 0 %
----------------------------------

The low flow volume will be displayed. According to the description in Section “12.4.3.2 Input window / modify a value”, the current value can be changed. After setting the new low flow volume, you confirm your entry with ↵.

### 13.4.3 Low flow cut-off hysteresis

The hysteresis of the low flow volume is the flow rate expressed as a percentage of the upper range value by which the volume must fall below or surpass the set low flow volume in order to activate or deactivate the function. The hysteresis of the low flow volume can be set in 0.1-percent increments from 0 to 10 %. After selecting the *Low flow cut-off hysteresis* function and pressing ↵, the following selection field will be displayed:

Low flow cut-off hysteresis <u>0</u> 0 %
---------------------------------------------

The current hysteresis will be displayed. According to the description in Section “12.4.3.2 Input window / modify a value”, the current value can be changed. After setting the new hysteresis value, you confirm your entry with ↵.



### 13.5 Flow functional class

The FLOW functional class is comprised of functions that affect lower- and upper-range values and the processing of the measured flow rates. In Programming mode, i.e. after a password has been entered, the operator can change the settings regarding flow.

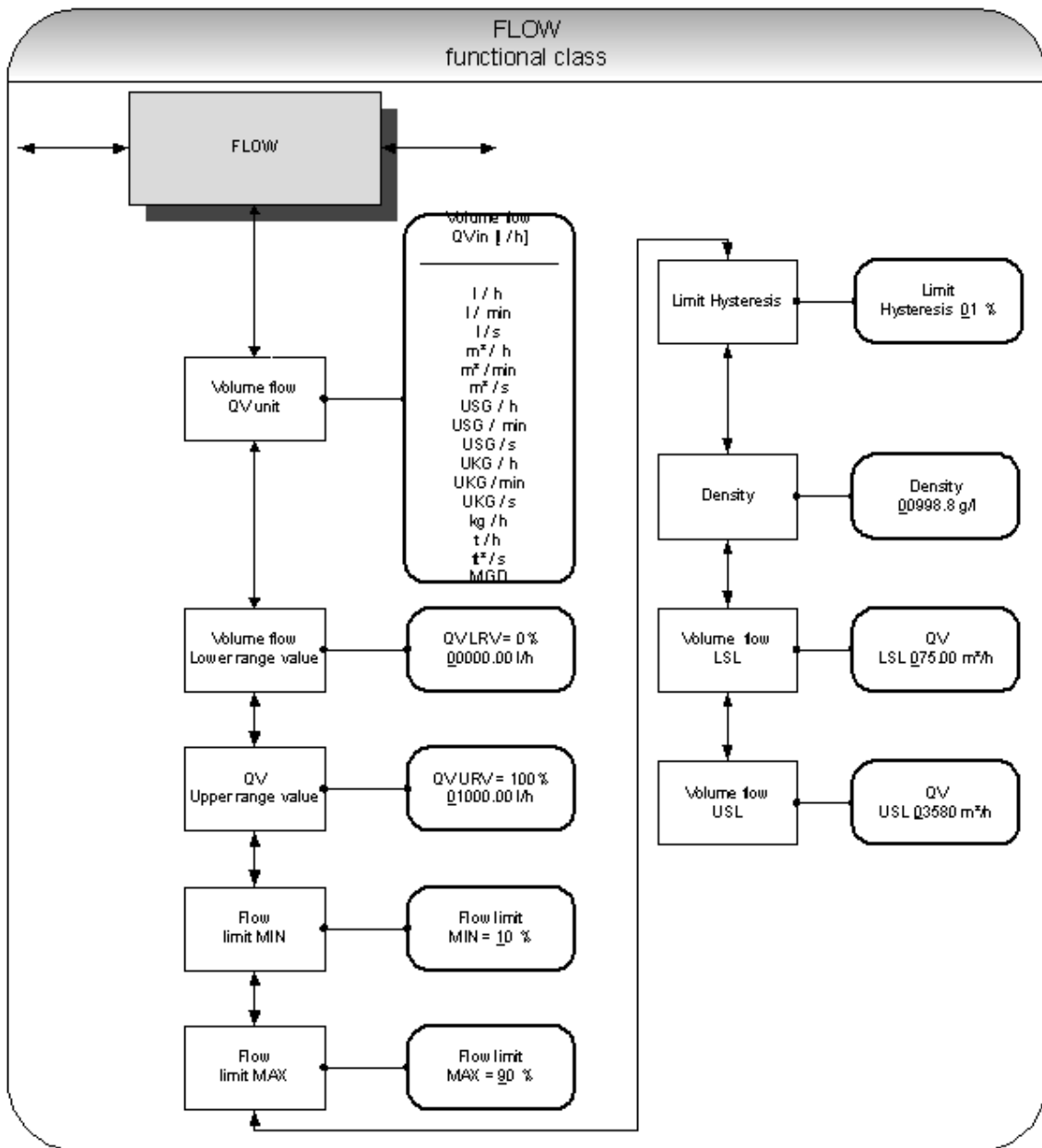

Figure 28 - Flow functional class

To change the current settings, enter the customer password. Otherwise, the settings can only be displayed but not changed. To cancel the current action, press Esc.

### 13.5.1 Volume flow QV unit

Using this function, the operator can define the physical unit for all display functions, limit values and the upper-range value of volume flow. After choosing the *Volume flow QV unit* function and pressing ↵, the following selection field will be displayed:

Volume flow QV in  
[l/h]

According to the description in Section “12.4.3.1 Selection window / make a selection”, one of the following units can be selected:

- l/h, l/min, l/s
- m<sup>3</sup>/h, m<sup>3</sup>/min, m<sup>3</sup>/s
- USG/h, USG/min, USG/s,
- UKG/h, UKG/min, UKG/s,
- Kg/h, t/h,
- ft<sup>3</sup>/s, MGD (Mega US Gallons / day).

Press ↵ to confirm and save the selection.

### 13.5.2 Volume flow lower-range value

This function allows the operator to set the lower-range value for volume flow. The lower-range value takes on the unit defined using the *Volume flow unit* function. The lower-range value will scale the current and frequency outputs assigned to volume flow. After choosing the *Volume flow lower-range value* function and pressing ↵, the following selection field will be displayed:

QV LRV = 0%  
XXXXX.XX l/h

The current lower-range value for volume flow will be displayed. According to the description in “Section 12.4.3.2 Input window / modify a value”, the current value can be changed.

### 13.5.3 Volume flow upper-range value

This function allows the operator to set the upper-range value for volume flow. The upper-range value takes on the unit defined using the *Volume flow unit* function. The upper-range value will scale the current and frequency outputs assigned to volume flow. After choosing the *Volume flow upper-range value* function and pressing ↵, the following selection field will be displayed:

QV URV = 0%  
XXXXX.XX l/h

The current upper-range value for volume flow will be displayed. According to the description in Section “12.4.3.2 Input window / modify a value”, the current value can be changed.

### 13.5.4 Volume flow limit MIN

The MIN limiting value for volume flow can be evaluated via the status output. You enter the value as a percentage of the set upper-range value. If the volume flow is lower than that limit value, the status output will be set in case the corresponding assignment has been made. If the alarm function has also been activated for the current output, the applied current will change to < 3.2 mA or > 20.5 mA / 22 mA. After choosing the *Volume flow limit MIN* function and pressing ↵, the following selection field will be displayed:

Volume flow limit MIN = <u>10</u> %
----------------------------------------

The current MIN upper-range value for volume flow will be displayed. According to the description in Section “12.4.3.2 Input window / modify a value”, the current value can be changed.

### 13.5.5 Volume flow limit MAX

The MAX limiting value for volume flow can be evaluated via the status output. You enter the value as a percentage of the set upper-range value. If the volume flow surpasses this limit value, the status output will be set in case the corresponding assignment has been made. If the alarm function has also been activated for the current output, the applied current will change to < 3.2 mA or > 20.5 mA / 22 mA. After choosing the *Volume flow limit MAX* function and pressing ↵, the following selection field will be displayed:

Volume flow limit MAX = <u>90</u> %
----------------------------------------

The current MAX upper-range value for volume flow will be displayed. According to the description in Section “12.4.3.2 Input window / modify a value”, the current value can be changed.

### 13.5.6 QV limit hysteresis

The hysteresis of the QV limiting values is the flow rate in percent based on the upper-range value and indicates the value which must fall below or surpass the set limiting values in order to activate or deactivate the function. The hysteresis of the QV limiting values can be set in 1-percent increments from 0 to 10 %. After choosing the *QV limit hysteresis* function and pressing ↵, the following selection field will be displayed:

QV limit Hysteresis <u>00</u> %
------------------------------------

The current hysteresis value will be displayed. According to the description in Section “12.4.3.2 Input window / modify a value”, the current value can be changed.

### 13.5.7 Density

If a mass unit in kg or t is used as flow unit (13.5.1 Volume flow QV unit), the density of the medium must be entered in the unit of g/l. Using the entered density value, the mass flow is calculated from the volume flow measurement.

After choosing the *Density* function and pressing ↵, the following selection field will be displayed:

Density 998.2 g/l
----------------------

The current density value will be displayed. According to the description in Section “12.4.3.2 Input window / modify a value”, the current value can be changed.



The value of the density is not measured. It is a parameter.

### 13.5.8 Volume flow LSL (information field)

This value represents the minimum lower range value based on the inside diameter of the sensor. This value is normally set for a flow velocity of 0.25 m/s.

QV LSL XX.XXX l/h
----------------------

### 13.5.9 Volume flow USL (information field)

This value represents the maximum upper range value based on the inside diameter of the sensor. This value is normally set for a flow velocity of 11 m/s.

QV USL XX.XXX l/h
----------------------

### 13.6 PULSE OUTPUT functional class

The PULSE OUTPUT functional class is comprised of the functions regarding the pulse output.

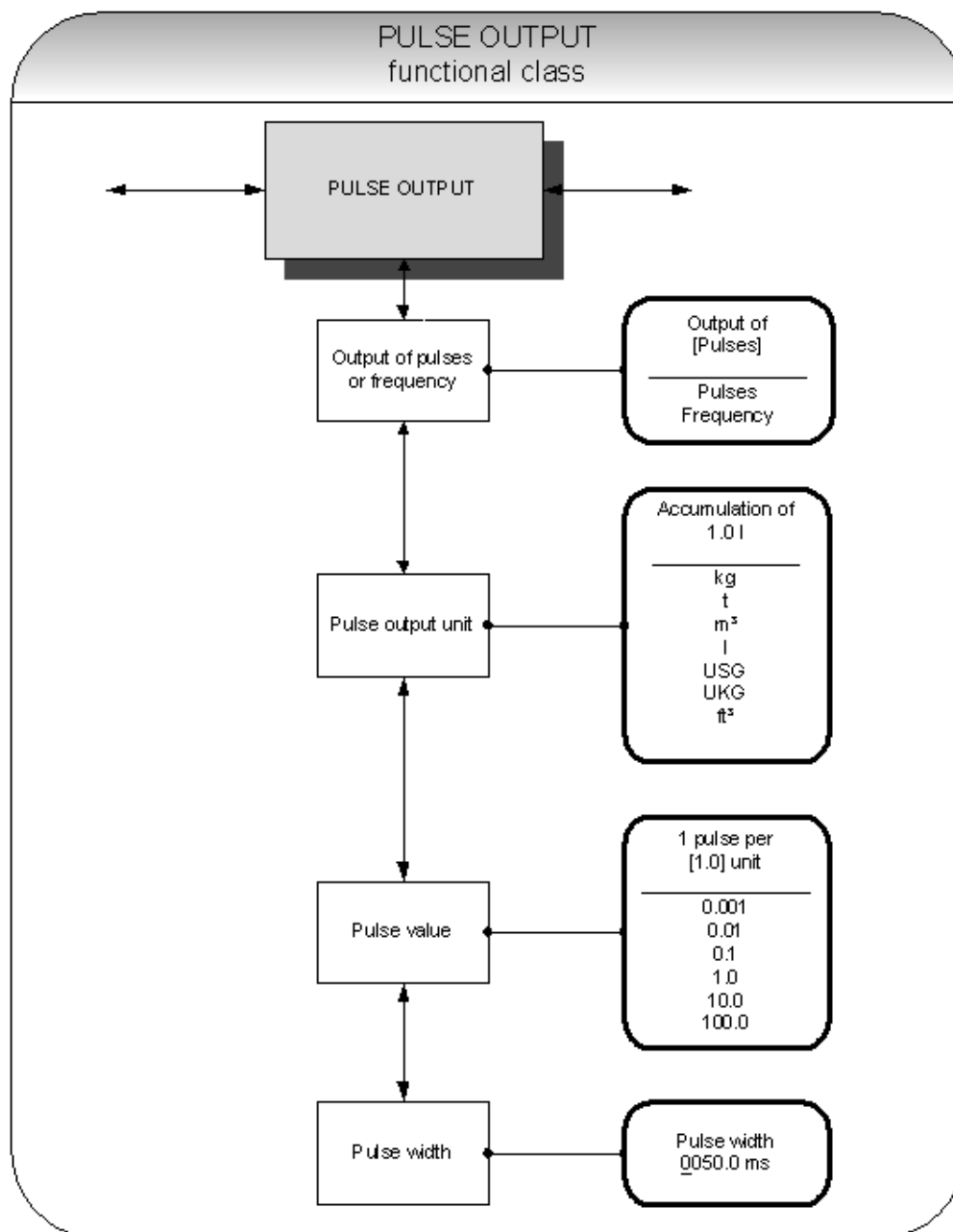

Figure 29 □ Pulse output functional class

### 13.6.1 Pulse Output

After selecting the pulse value and unit the transmitter will determine the number of pulses per flow volume. When choosing a combination of these settings that cannot be fulfilled in real time for the upper-range value (e.g. the number of pulses per unit time cannot be generated because the pulse width is too large), an error message will appear.

Press  $\downarrow$  to display the current setting:

Output of  
[Pulses]

According to the description in Section “12.4.3.1 Selection window / make a selection”, the operator can toggle between frequency and pulse output (default setting).

### 13.6.2 Pulse output unit

This function allows the operator to define the unit to be counted. After selecting the *Pulse output unit* function, press  $\downarrow$  to display the following selection field:

Accumulation of  
1.0 l

The current value will be displayed. As mentioned in Section “12.4.3.1 Selection window / make a selection”, the operator can choose between the following units:

- Mass units:
  - kg, t
- Volume units:
  - m<sup>3</sup>, l, USG, UKG, ft<sup>3</sup>.

### 13.6.3 Pulse value

This function allows the operator to define how many pulses will be output per unit counted. After selecting the *Pulse value* function, press  $\downarrow$  to display the current unit:

1 pulse per  
[1.0] unit

As mentioned in Section “12.4.3.1 Selection window / make a selection”, the operator can choose between the following pulse values:

- Values:
  - 0.001, 0.01, 0.1, 1.0, 10.0, 100.0

### 13.6.4 Pulse width

This function allows the operator to change the width of the output pulse to be output. If the pulse width is too large for the actual pulse number, it will be reduced automatically. In this case the warning “Pulse output saturated” will be displayed.

After selecting the *Pulse width* function, press  $\downarrow$  to display the following selection field:

Pulse width <u>0</u> 050.0 ms
----------------------------------

The current pulse width will be displayed. As mentioned in Section 12.4.3.2 Input window / modify a value”, the operator can change the current value.

The maximum output frequency can be calculated from the following formula:

$$f = \frac{1}{2 * pulse\ width[s]} \leq 1000\ Hz$$

If connecting to electrical counter relays, we recommend pulse widths greater than 4 ms; for electromechanical counter relays the pre set value should be 50 ms.

### 13.7 STATUS OUTPUT functional class

The functional class OUTPUT is comprised of the functions for setting the status output.

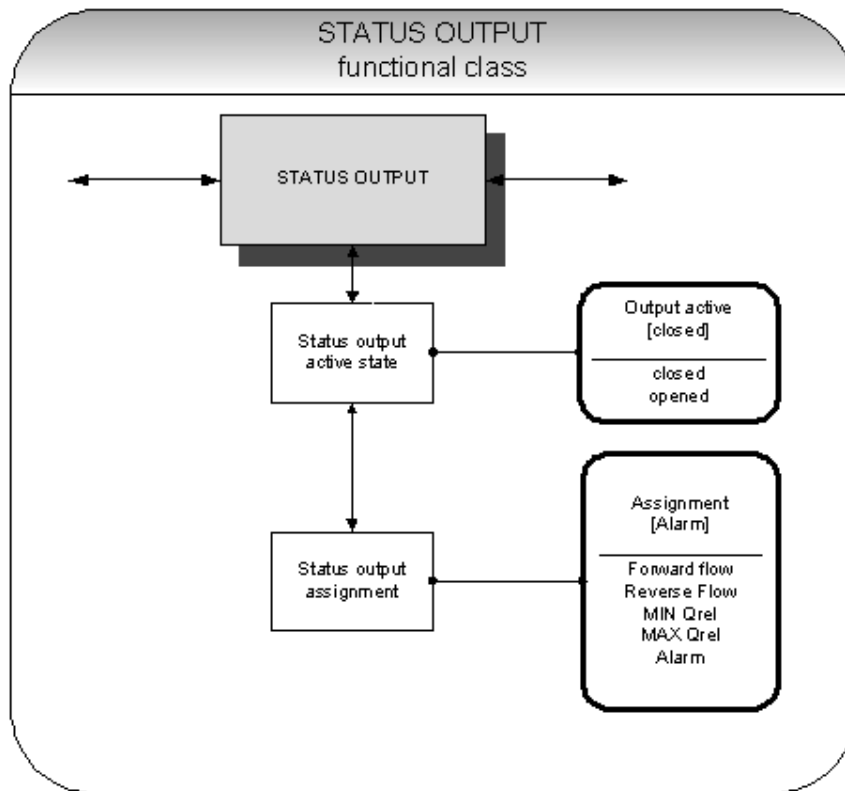

Figure 30 □ Status output functional class

#### 13.7.1 Status output active state

The status output can be compared to an electrical relay that can function as make or break contact. For safety-relevant applications, the operator will choose the break contact setting so that a power failure or failure of the electronics can be detected like an alarm. In standard applications, the output is used as make contact.

The *Status output state active state* function allows the operator to define the behavior of the status output.

Output active  
[closed]

As mentioned in Section 12.4.3.1 Selection window / make a selection, the operator can choose between the following settings:

- Closed.
- Open.

### 13.7.2 Status output assignment

This function allows the operator to define to which event the status output is to be assigned. The most common option is the reverse flow assignment.

After selecting the *Status output assignment* function, press ↵ to display the current assignment.

Output assigned to  
[Reverse flow]

As mentioned in Section 12.4.3.1 Selection window / make a selection, the operator can choose between the following settings:

- Flow direction recognition
  - Forward flow
  - Reverse flow
- Limiting values:
  - MIN QV
  - MAX QV
- All limiting values and error detection
  - Alarm.



## 13.8 CURRENT OUTPUT functional class

The CURRENT OUTPUT functional class allows the operator to perform the settings for the current outputs of the transmitter.

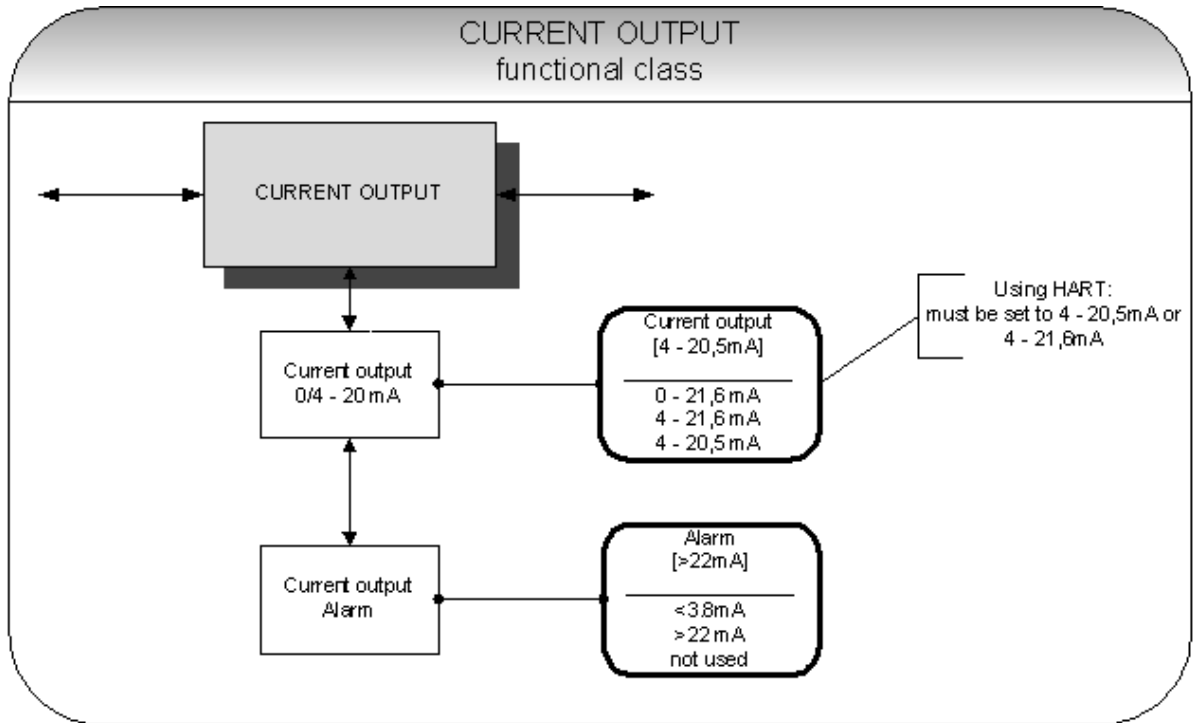

Figure 31 □ Current output functional class

The current output is always assigned to volume flow.

### 13.8.1 Current output 0/4 - 20 mA

The *Current output 0/4 to 20 mA* function allows the operator to define the range in which the current output is to be operated. Within the range from 0 to 21.6 mA (= 0 ... 110 %) HART® communication is not possible. The range from 4 to 20.5 mA follows the NAMUR recommendation and covers the range from 0 to 104 % of the measuring range. The standard range from 4 to 21.6 mA allows for a control of the measuring range of up to 110 %.

Press  $\downarrow$  to display the current setting.

Current output I1  
[4] – 21.6 mA

As mentioned in Section 12.4.3.1 Selection window / make a selection, the operator can choose between the following settings:

- 0 – 21.6 mA
- 4 – 21.6 mA
- 4 – 20.5 mA

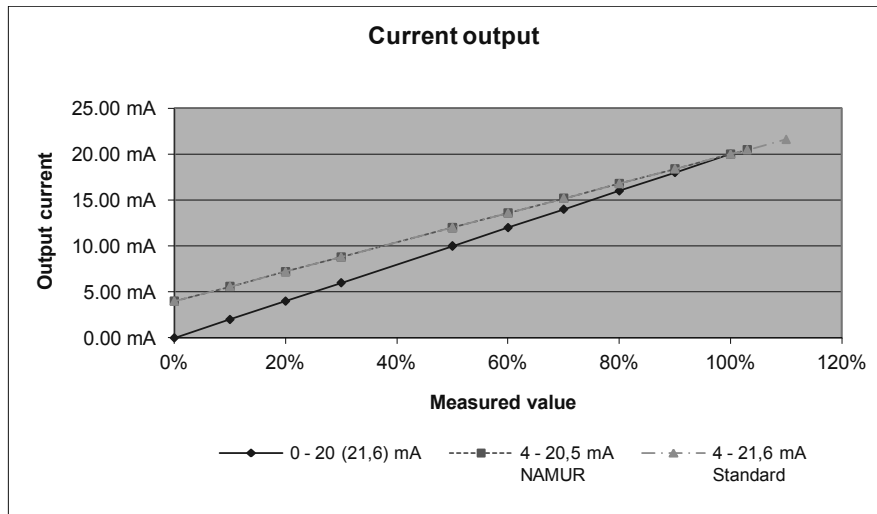

Fig. 32 □ Current output

### 13.8.2 Current output alarm

This function allows the operator to define the state taken on by the current output when a state of alarm is detected. This information can be analyzed in the control system. Press ↵ to display the current setting:

Alarm  
[>22mA]

As mentioned in Section 12.4.3.1 Selection window / make a selection, the operator can choose between the following settings:

- not used            no alarm function
- > 22 mA            current rise in the case of an alarm
- < 3.8 mA            current reduction in the case of an alarm

### 13.9 SIMULATION functional class

The functional class SIMULATION is comprised of the functions for simulating the outputs. If simulation is activated, all output signals will be generated based on the selected type of simulation. The peripherals connected to the device can be tested without a flowing product.

Simulation will be deactivated automatically if the operator switched the device off or did not touch any control unit keys for about 10 minutes. Simulation can also be activated and controlled via HART® commands.

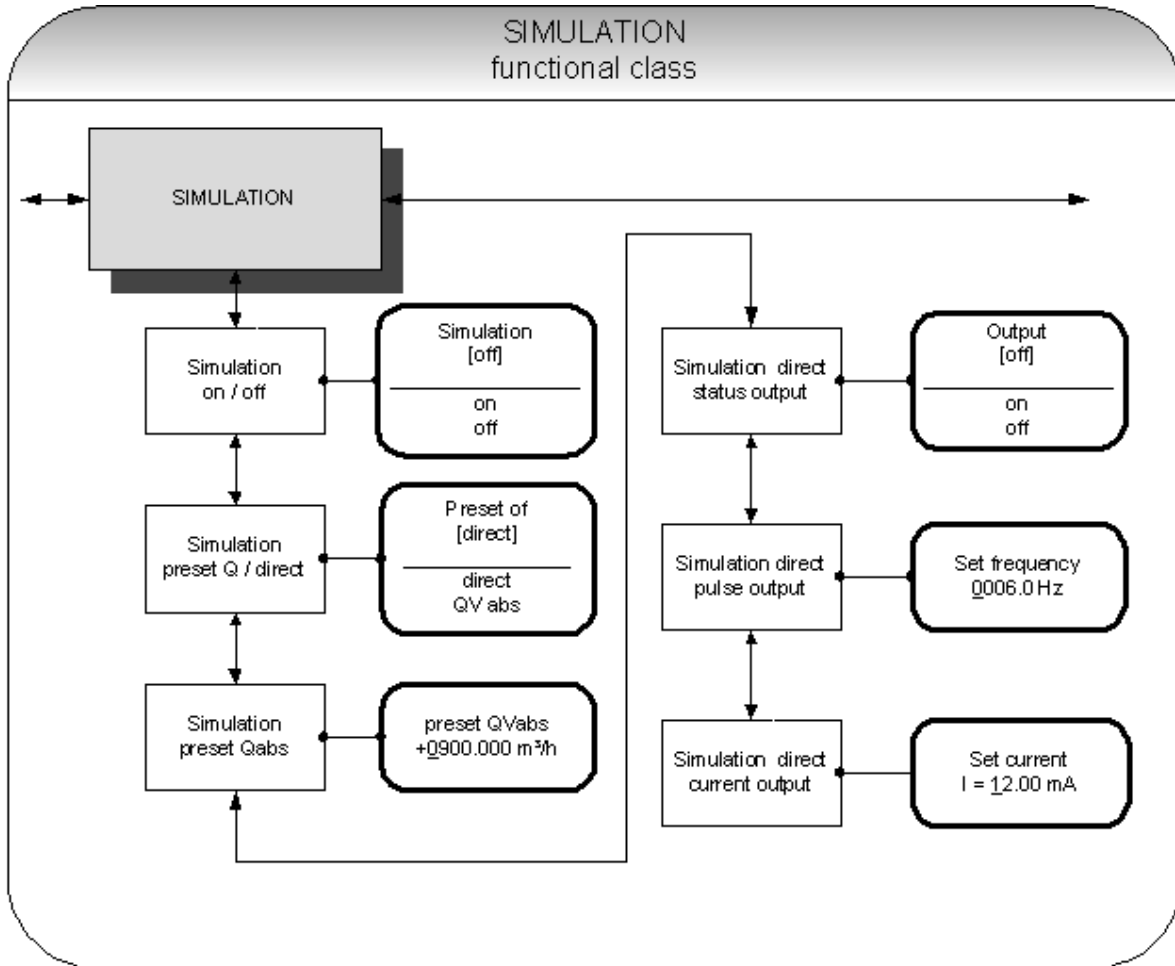

Figure 33 □ Simulator functional class

### 13.9.1 Simulation on / off

The *Simulation on/off* function allows the operator to activate or deactivate simulation. If simulation is activated, all output signals will be generated based on the selected type of simulation. The peripherals connected to the device can be tested without a flowing product. Press  $\downarrow$  to display the current status.

Simulation  
[off]

As mentioned in Section 12.4.3.1 Selection window / make a selection, the operator toggles between the “on” and “off.”

Simulation will be deactivated automatically if the operator switched the device off or did not touch any control unit keys for about 10 minutes.

### 13.9.2 Simulation direct / preset value Q

This function allows the operator to define whether simulation is comprised of the measurement of the volume flow or whether the outputs will be set directly. Press  $\downarrow$  to display the selected type of simulation.

Simulation  
[direct]

As mentioned in Section 12.4.3.1 Selection window / make a selection, the operator can choose between the following settings:

- Direct            pulse and current outputs are programmed directly
- QV<sub>abs</sub>           a measurement is simulated

If “direct” simulation is activated, any output will perform based on the settings described in Sections 13.9.4. It is therefore recommended that the settings be defined before starting simulation. They can then be purposefully changed during simulation.



Simulation will be deactivated automatically if the operator switched the device off or did not touch any control unit keys for about 10 minutes.

### 13.9.3 Simulation measured flow Q

If the operator selected the setting “QV<sub>abs</sub>” described in Section 13.9.2 Simulation direct / preset value Q, the following settings of a volume flow will affect the output behavior during measured value simulation.

In order to simulate volume flow, the operator can define a “measured value.” The flow rates will be simulated in both directions. All outputs will perform based on the simulated measured value.

Preset QVabs  
±0900.0 l/h

The simulation value is entered as described in Section “12.4.3.2 Input window / modify a value”.

### 13.9.4 Direct simulation of outputs

If the operator selected the setting “Direct simulation” described in Section “13.9.2 Simulation direct”, the following 3 possible settings will affect the output. All outputs are simulated at the same time by these settings.

#### **13.9.4.1 Status output simulation**

The *Status output simulation* function allows the operator to purposefully activate the status output. Press  $\downarrow$  to display the current state.

Status output  
[off]

As mentioned in Section 12.4.3.1 Selection window / make a selection, the operator can toggle between “on” and “off”.

#### **13.9.4.2 Pulse output simulation**

The *Pulse output simulation* function allows the operator to define a frequency to be assigned to the pulse output. After selecting this function and pressing  $\downarrow$ , the following selection field will be displayed:

Set frequency  
0210.0 Hz

This field shows the current frequency. As mentioned in Section “12.4.3.2 Input window / modify a value”, the definable frequency ranges from 6 Hz to 1100 Hz.

#### **13.9.4.3 Current output simulation**

This function allows the operator to define a current for current interface 1. Press  $\downarrow$  to display the set current.

Set I1  
I1 = 10.50 mA

As mentioned in Section “12.4.3.2 Input window / modify a value”, the current value can be changed.

### 13.10 SELF-TEST functional class

The SELF-TEST function class is comprised of the functions relating to the self-test of the sensor. The diagnostic functions of the transmitter, which monitor the proper functioning of the electronics and the software, are always active and cannot be switched off. The excitation current can be monitored in addition.

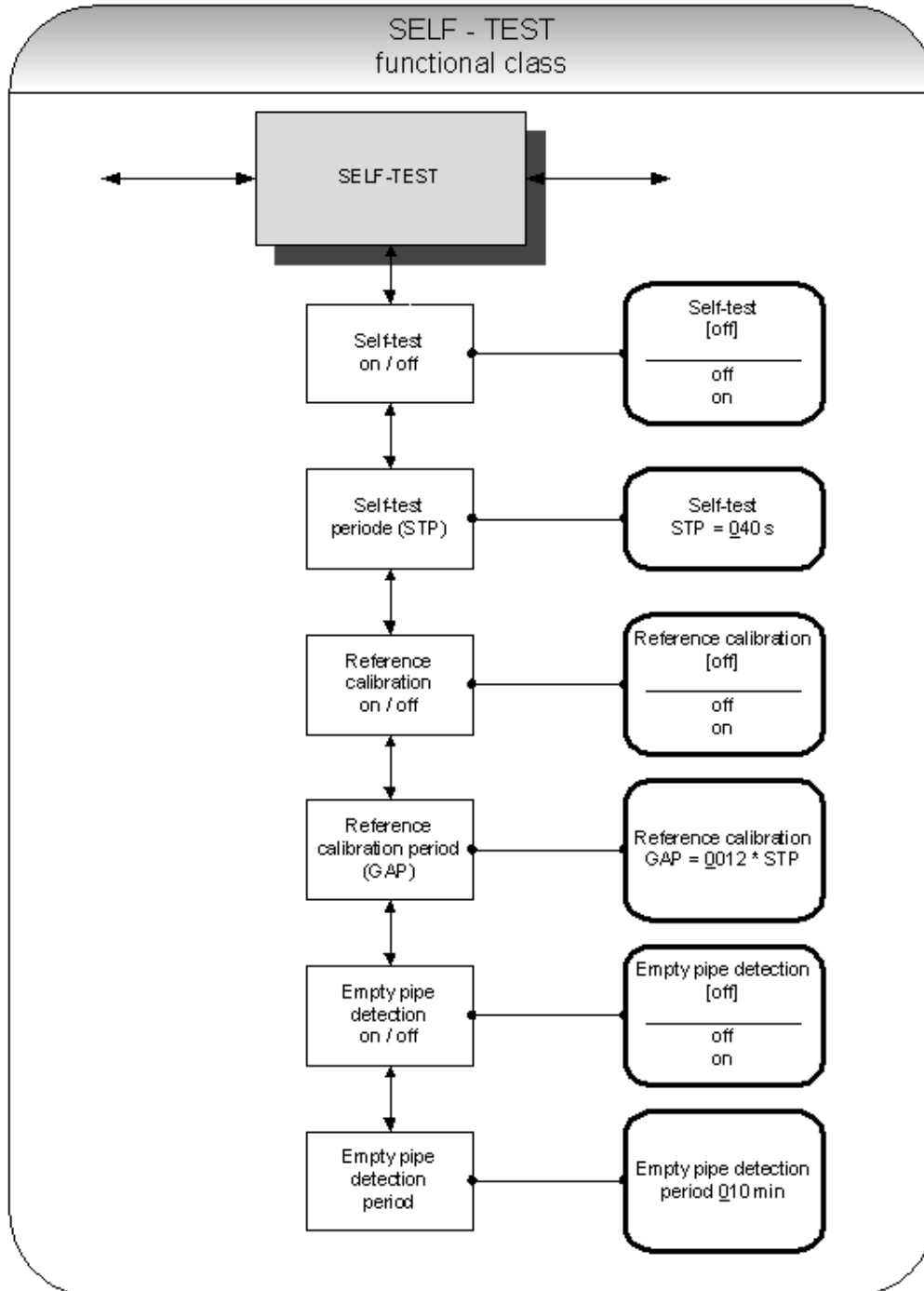

Figure 34 - SELF-TEST function class

### 13.10.1 Self-test test on / off

The *Self-test on/off* function allows the operator to activate or deactivate the monitoring function of the field coil current.

Self-test [off]
--------------------

According to the description in Section 12.4.3.1 Selection window / make a selection, the operator can toggle between “on” and “off.” The standard factory setting is “off.”

The measurement is intended to suppress temperature dependences of the transmitter. During the sampling time of 0.5 seconds, the transmitter is offline; the last measured value will be displayed at the signal outputs.

### 13.10.2 Self-test period (STP)

With the help of this function, you set the time period after which the field coil current will be measured periodically. You can set periods between 35 seconds and 999 seconds.

Self-test STP = 040 s
--------------------------

This field shows the current self-test period. As mentioned in Section “12.4.3.2 Input window / modify a value”, the current value can be changed.

### 13.10.3 Reference calibration on / off

With the help of the function *Reference calibration on/off*, the periodic recalibration of the transmitter can be activated or deactivated. The objectives of the function are periodic self-monitoring and an increase in long-term stability. During the automatic reference calibration of 30 seconds, the transmitter is offline; the last measured value will be displayed at the signal outputs. After choosing this function and pressing ↵, the following selection field will be displayed:

Reference calibration [off]
--------------------------------

According to the description in Section 12.4.3.1 Selection window / make a selection, the operator can toggle between “on” and “off.” If switched on, the reference calibration will be done periodically.

#### 13.10.4 Reference calibration period (GAP)

The function *Reference calibration period* is a multiplication of the function “self-test period”. With the help of this function, you define after how many STP’s the reference calibration is to be performed.

Reference calibration GAP = 540 * STP
------------------------------------------

This field shows the current reference calibration period. As mentioned in Section “12.4.3.2 Input window / modify a value”, the current value can be changed.

Example: The “self-test period” has been set to 40 seconds; a reference calibration is to be carried out every 6 hours.

$$\text{GAP} = 6 * 3600\text{s} / 40\text{s} = 540$$

#### 13.10.5 Empty pipe detection on / off

With the help of the function *Empty pipe detection on / off*, continuous empty-pipe detection can be activated or deactivated. After selecting this function and pressing ↵, the following selection field will be displayed:

Empty pipe detection [ off ]
---------------------------------

According to the description in Section 12.4.3.1 Selection window / make a selection, the operator can toggle between “on” and “off.” If switched on, the empty pipe detection will be done periodically.

#### 13.10.6 Empty pipe detection period

With the help of the function *Empty pipe detection period*, the time after which the detection will be carried out can be set. When entered 0 minutes, the detection will be performed continuously. After choosing this function and pressing ↵, the following selection field will be displayed:

Empty pipe every 0 Min
---------------------------

This field shows the current empty pipe detection period. As mentioned in Section “12.4.3.2 Input window / modify a value”, the current value can be changed.



### 13.11 SETTINGS SENSOR + MA1 functional class

This functional class is comprised of the general settings affecting the behavior of the transmitter.

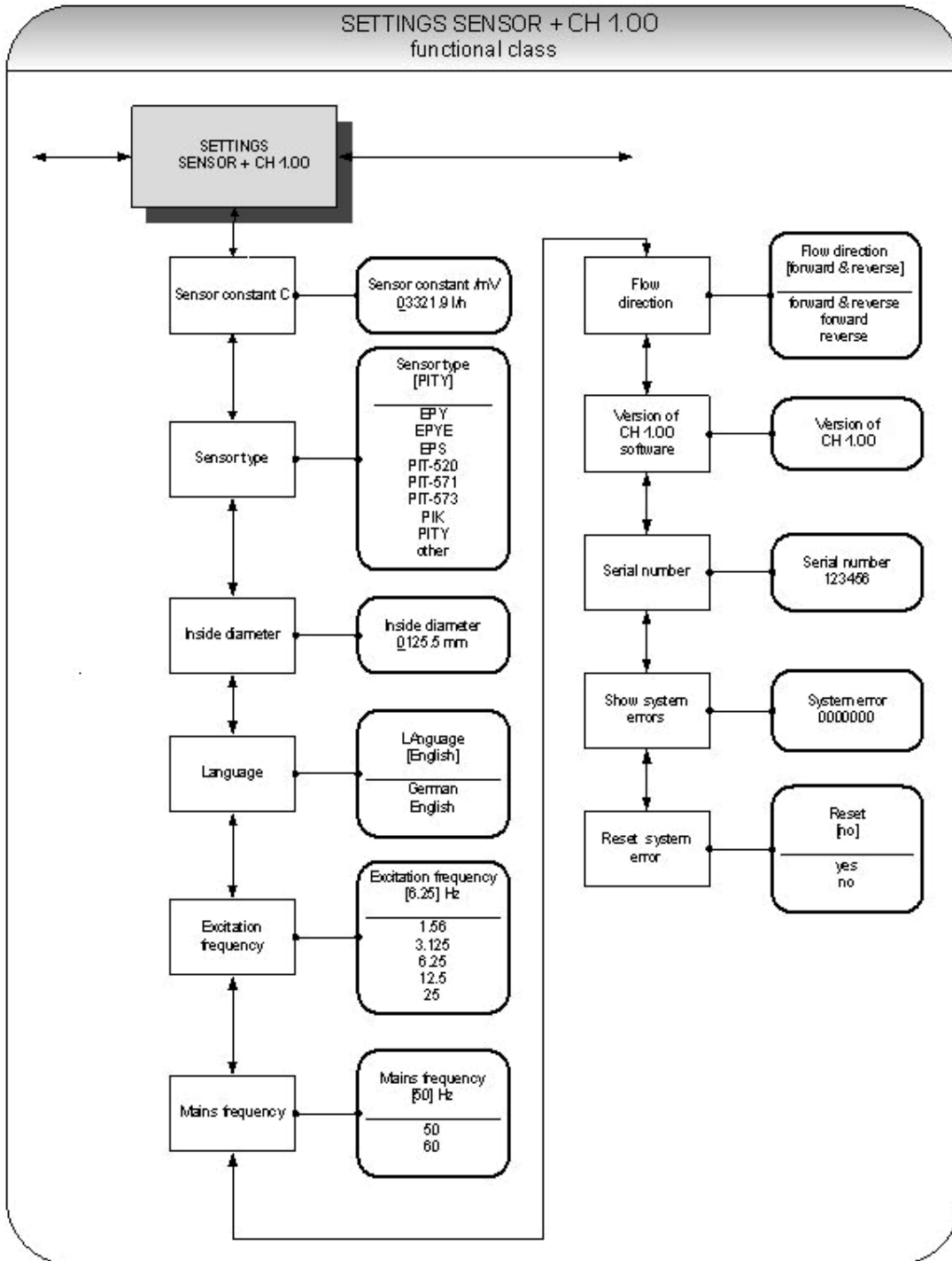

Figure 35 □ Settings sensor + MA1 functional class

### 13.11.1 Sensor constant C

The sensor constant C is the calibration value of the sensor connected to the transmitter. The calibration value must be entered in the MA1 to ensure a correct measurement. The constant will be defined after the calibration of the meters and can be found on the rating plate of the sensor. After selecting the *Sensor constant* function, press ↵ to display the current setting.

Sensor constant /mV 01234.56 l/h
-------------------------------------

As mentioned in Section “12.4.3.2 Input window / modify a value”, the current value can be changed.



**CAUTION:**

Changing sensor constant C to a value that differs from the value on the rating plate of the sensor connected to the flow meter will result in false readings!

**Note:**

The sensor constant must always be preceded by a plus or minus sign. The delivery default setting is a plus sign. If inlet and outlet section are interchanged when the device is installed (the flow direction is indicated by an arrow on the sensor), the transmitter will display a “forward flow” negative measurement value. If the (plus or minus) sign of the sensor constant is then changed without changing the actual value, a plus sign will again be displayed. No changes need be made in the disposition of the electrical connections (wires).

### 13.11.2 Sensor type

The function *Sensor type* contains the type of the sensor with which the transmitter has been delivered. The distinction is necessary and required because the flow rate measurement uses different calculations depending on the type of sensor. After selecting this function, press ↵ to display the current setting.

Sensor type [ PITY ]
-------------------------

This type code can be found on the sensor rating plate. This setting is defined by the vendor when the device is first put into operation at the factory. It should only be changed if the transmitter is mounted onto another sensor.

### 13.11.3 Inside diameter

The inside diameter of the sensor connected to the transmitter is necessary for calculating the mean flow velocity. The inside diameter must be checked in the MA1 (on mm exact) to ensure a correct measurement. After choosing the function “inside diameter” and pressing ↵, the following selection field will be displayed:

Inside diameter 50 mm
--------------------------

As mentioned in Section “12.4.3.2 Input window / modify a value”, the current value can be changed.

### 13.11.4 Language

Two languages are available in the control unit: German and English.

Language  
[English]

As mentioned in Section 12.4.3.1 Selection window / make a selection, the operator can toggle between these languages:

- German,
- English.

### 13.11.5 Excitation frequency

With the help of the function *Excitation frequency*, you can set the excitation frequency of the field coil current. Since the excitation frequency depends on the sensor, it cannot be assigned freely. The excitation frequency defaults to 6.25 Hz.

Excitation frequency  
[ 6.25 Hz ]

The selection is confirmed and taken over with the ↵-key.



#### Caution!

If the excitation frequency is changed, then a reference calibration must be accomplished. Otherwise the measuring accuracy is not ensured.

### 13.11.6 Mains frequency

In order to ensure the mains frequency (50 Hz or 60 Hz) optimal interference suppression, the input of the frequency is necessary. The standard setting is 60 Hz.

After choosing the function *Mains frequency* and pressing ↵, the following selection field will be displayed:

Mains frequency  
[60 Hz]

The selection is confirmed and taken over with the ↵-key.

### 13.11.7 Flow direction

This function allows the operator to define the flow direction that the transmitter will evaluate. Only “forward” should be selected to prevent reverse flow from being measured. The standard factory setting is “forward & reverse.” After selecting the *Flow direction* function, press ↵ to display the current setting.

Flow direction  
[forward]

As mentioned in Section 12.4.3.1 Selection window / make a selection the operator can choose between:

- forward
- reverse
- forward & reverse

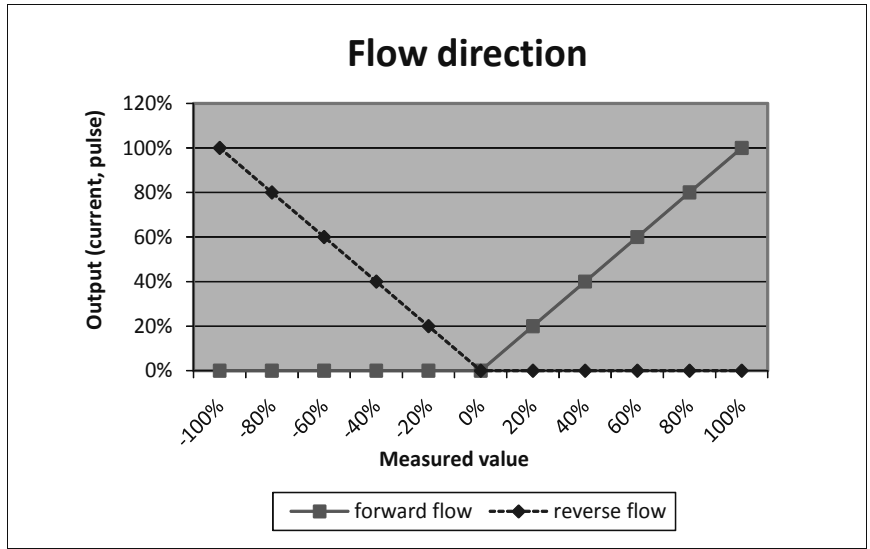

Figure 36 □ Flow direction

**13.11.8 Software version (information field)**

After selecting this function, the version of the transmitter software will be shown (example: 1.06):

Version of MA1  
001.06

**13.11.9 Serial number (information field)**

With the help of the *Serial number* function, the transmitter is assigned to an order. This number provides access to internal vendor data if the device needs servicing. The serial number is printed on the rating plate of the transmitter. After selecting this function, press ↵ to display the following information field:

Serial number:  
100683

This entry should never be changed so as to ensure that the sensor, the transmitter and the documents created within quality management are assigned correctly.

**13.11.10 Show system errors**

With the help of this function, you can show the error code of the system errors that have occurred.

The integrated diagnostic system of the MA1 distinguishes between two types of errors. **Self-test errors** such as problems with a sensor line or inconsistent parameter inputs are displayed as textual error messages. Once the error has been eliminated, the message automatically disappears from the display.

Errors that are attributed to system memory or software, division by zero, or a fault in the electronics unit are designated as **system errors**. These error messages are not reset automatically after the error (usually of very brief duration) is eliminated.

Section 14 has more information on error messages.

### 13.11.11 Reset system error

Before resetting a system error manually, we advise that you look up what the error was in the Error section of the manual.

Reset error [no]
---------------------

If the operator toggles to [yes] and confirms the action according to the description in Section 12.4.3.1 Selection window / make a selection, the error messages disappears from the display. If the message reappears shortly after, contact our technical service department.

## **14. MA1 ERROR MESSAGES**

### **14.1 List of error messages**

#### **14.1.1 Display of self-test errors**

Self-test errors are displayed as plain text in the set language (German or English) on the second line of the LCD.

<b>Display (German)</b>	<b>Display (English)</b>	<b>Description</b>	<b>Possible cause of error and remedy</b>
Rohr leer	empty pipe	Empty-pipe detection has been activated. Fluid density is below the limit value for density; empty-pipe detection, pipe is empty.	Product contains air bubbles/pipe is empty. Bubble-free filling must be ensured.
Spulenstrom	Exciter current	Interruption / short circuit in the connection of excitation coil. All signal outputs will be set to no flow.	Check the wiring between transmitter and sensor.
Messkreis überst.	meas. circ. sat.	The flow measurement circuit is overloaded. The measured electrode voltage is too high. All signal outputs will be set to no flow.	Flow rate exceeds the upper range value (URL). High electrostatic voltage at the electrodes.
Strom überst.	curr. saturated	The output of current interface is overloaded. Based on the selected settings and the currently assigned measured variable, the current output is > 21.6 mA.	Check the upper-range value and the flow rate settings.
IMP übersteuert	pulse out satur.	The pulse output is overloaded. The current measured value requires a pulse rate, which can no longer be generated with the help of the set pulse duration and pulse value.	Check pulse duration, pulse value, and measuring range. Check the flow rate.

Display (German)	Display (English)	Description	Possible cause of error and remedy
Parameter inkons.	params inconsist	Parameter is inconsistent.	Check the parameter settings. The set parameters are contradictory. Example: Upper-range value, pulse value and pulse duration must be matched in such a way that the combination fits for all measured values.
ext EEPROM fehlt	missing EEPROM	The data memory module (DSM) with the calibration data of the sensor and the customer-specific settings of the transmitter is not plugged-in.	Insert the data storage module (DSM) in the socket on the power supply board MA1.

**Table 9 - Display of self-test errors**

	<p><b>Information</b> <input type="checkbox"/> <b>Error message:</b> <input type="checkbox"/> <b>Parameter is inconsistent</b> <input type="checkbox"/> <b>(system error 0x0400)?</b></p> <p>To generate a list of the inconsistencies, first enter a valid password and then an invalid password. The control unit will show a list of current errors (only once). The operator can then correct the inconsistent settings after entering a valid password.</p>
-----------------------------------------------------------------------------------	------------------------------------------------------------------------------------------------------------------------------------------------------------------------------------------------------------------------------------------------------------------------------------------------------------------------------------------------------------------------------------------------------------------------------------------------------------------

#### 14.1.2 Display of system error

System errors consist of the message text “system error” and a 5-digit number in hexadecimal code. The meaning of the individual error codes is described in the following table. If several errors occur at the same time, the hexadecimal sum of the individual errors will be displayed. The errors are coded in such a way that the individual errors can be easily identified. The sums are unique.

Descriptor label (never displayed)	Constant/ display	Description
SystemfehlerExtEEProm	0x00002	External EEPROM (data memory chip DSM) plugged in but empty, not initialized
SystemfehlerIntEEProm	0x00004	Internal EEPROM (calibration MA1) erased, MA1 not calibrated
SystemfehlerEEPROM	0x00010	Unsuccessful saving or reading of memory data / defective memory

**Table 10 - Display of system error**

#### 14.1.3 Reset system error

After the fault recovery the displayed system error message can be reset.

- For this purpose the customer password has to be entered.
- Select the function Show system error. (Refer to 13.11.10 Show system errors). Analyze the fault and repair the transmitter or sensor.
- Finally reset the system error message. (Refer to 13.11.11 Reset system error)

## **15. Warranty**

The warranty period is from the date of shipment and continues for 24 months or 18 months from the date of installation, whichever is longer. If returned within the warranty period; and, upon factory inspection of the control, the cause of the claim is determined to be covered under the warranty; then, MAGNETROL will repair or replace the control at no cost to the purchaser (or owner) other than transportation.

MAGNETROL shall not be liable for misapplication, labor claims, direct or consequential damage or expense arising from the installation or use of equipment. There are no other warranties expressed or implied, except special written warranties covering some MAGNETROL products.

### **Notice of Copyright and Limitations**

MAGNETROL® & Magnetrol® logotype are registered trademarks of MAGNETROL® International, Incorporated.

Copyright © 2013 MAGNETROL® International, Incorporated.

All rights reserved.

MAGNETROL reserves the right to make changes to the product described in this manual at any time without notice. MAGNETROL makes no warranty with respect to the accuracy of the information in this manual.



CORPORATE HEADQUARTERS

705 Enterprise Street • Aurora, Illinois 60504-8149 USA

Phone: 630-969-4000 • Fax: 630-969-9489

magnetrol.com • info@magnetrol.com

EUROPEAN HEADQUARTERS

Heikensstraat 6 • 9240 Zele, Belgium

Phone: 052 45.11.11 • Fax: 052 45.09.93

---

BRAZIL: Av. Dr. Mauro Lindemberg Monteiro, 185, Quadrante 16 • CEP 06278-010 • Osasco • São Paulo

CANADA: 145 Jardin Drive, Units 1 & 2 • Concord, Ontario L4K 1X7

CHINA: Plant 6, No. 191, Huaqin Road • Minhang District • Shanghai 201108

DEUTSCHLAND: Alte Ziegelei 2-4 • D-51491 Overath

DUBAI: DAFZA Office 5EA 722, P.O. Box 293671 • Dubai, United Arab Emirates

INDIA: C-20 Community Centre • Janakpuri, New Delhi 110 058

ITALIA: Via Arese, 12 • 20159 Milano

RUSSIA: 198095, Saint-Petersburg • Marshala Govorova Street, House 35A, Office 532

SINGAPORE: 33 Ubi Avenue 3 • #05-10 Vertex • Singapore 408868

UNITED KINGDOM: Regent Business Centre • Jubilee Road • Burgess Hill, West Sussex RH15 9TL

Magnetrol & Magnetrol logotype, Orion Instruments & Orion Instruments logotype, Echotel, Eclipse, Modulevel, Pulsar, Tuffy and Aurora are registered trademarks of Magnetrol International, Incorporated.

Copyright © 2013 Magnetrol International, Incorporated. All rights reserved. Printed in the USA.

**Bulletin: 62-600.0 • Effective: October 2013**